

ORIGINAL INSTRUCTIONS

SHIBUYA

DIAMOND CORE DRILLING MACHINE OPERATOR'S INSTRUCTION MANUAL

WITH PARTS LISTS & DRAWINGS

DRILL MOTOR MODEL: H2021

DRILL STAND MODEL: TS-255 800L/TS-255 1000L/TS-255(AB52) 1000L

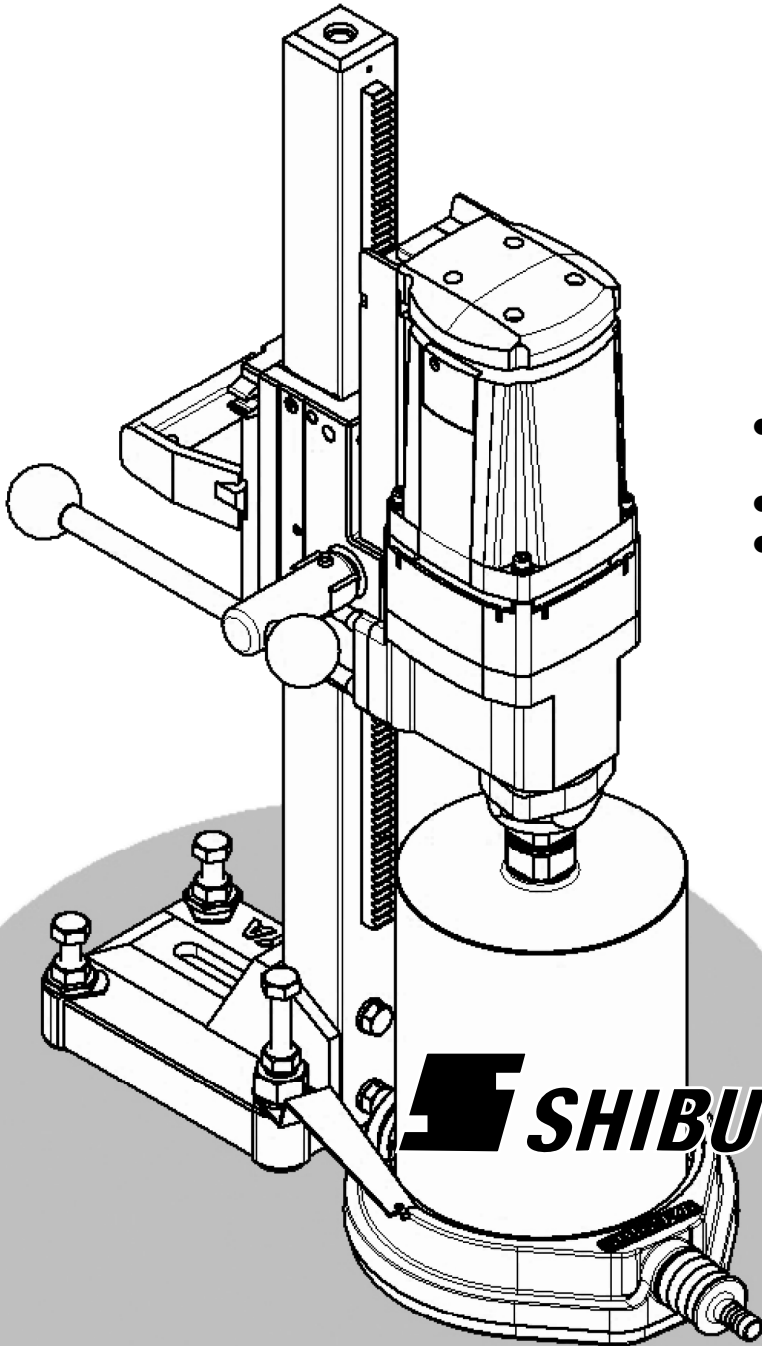

- Make sure to read and understand this manual thoroughly before starting the operation.
- Always keep this manual with the machine.
- Make sure that this manual is with the machine, when it is given and/or sold to other people.

SHIBUYA COMPANY, LTD.

5-86 MOKUZAIKO-KITA, HATSUKAICHI
HIROSHIMA 738-0021
JAPAN
TEL: +81-829-34-4510

TS-255-H2021-2023

NAME OF EACH PART

H2021 Drill Motor

1. Gear Box
2. Motor
3. Spindle
4. Grease Inlet
5. GARDENA Connector / Water Cock
6. Main Switch (Circuit Protector)
7. Swivel Ring
8. Gear Change Knob
9. Air Inlet
10. Air Outlet
11. Power Cord
12. Water Leakage Hole
13. PRCD (220-240 V model only)
14. Carriage Block
15. Stopper-Knob (Carriage Brake)
16. Grip Handle
17. Quick Release Handle (Feed Handle)

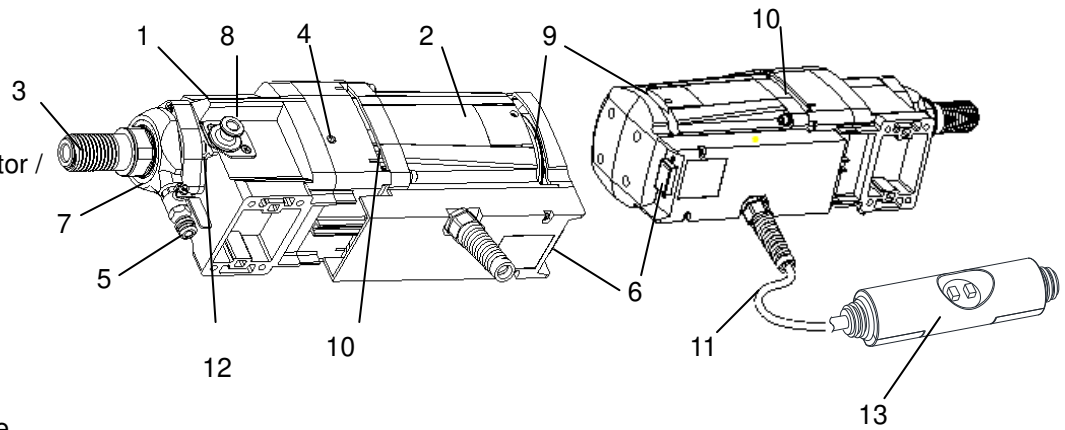

TS-255 Drill Stand

18. Column
19. Anchor Slot
20. Leveling Bolt
21. Base
22. Beam
23. U-Nut

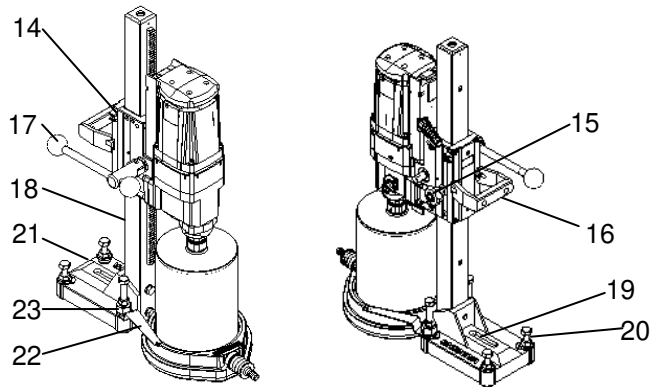

TS-255(AB52) Drill Stand

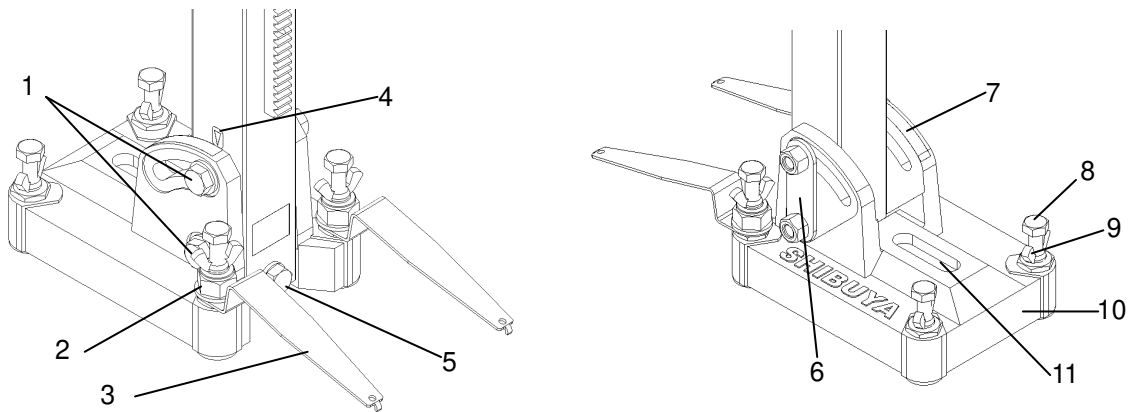

- | | |
|---------------------|------------------|
| 1. Hex Bolt M12x90 | 7. Angle Scale |
| 2. U-Nut | 8. Leveling Bolt |
| 3. Beam | 9. Flange Nut |
| 4. Indication label | 10. Base |
| 5. Hex Bolt M12x70 | 11. Anchor Slot |
| 6. Plate | |

Refer to the schematic drawings and parts lists attached at the end of this manual for names of more specific parts.

ILLUSTRATIONS OF OPERATION

(The numbers in the figure correspond to the same heading number in the writing sections.)

7.1

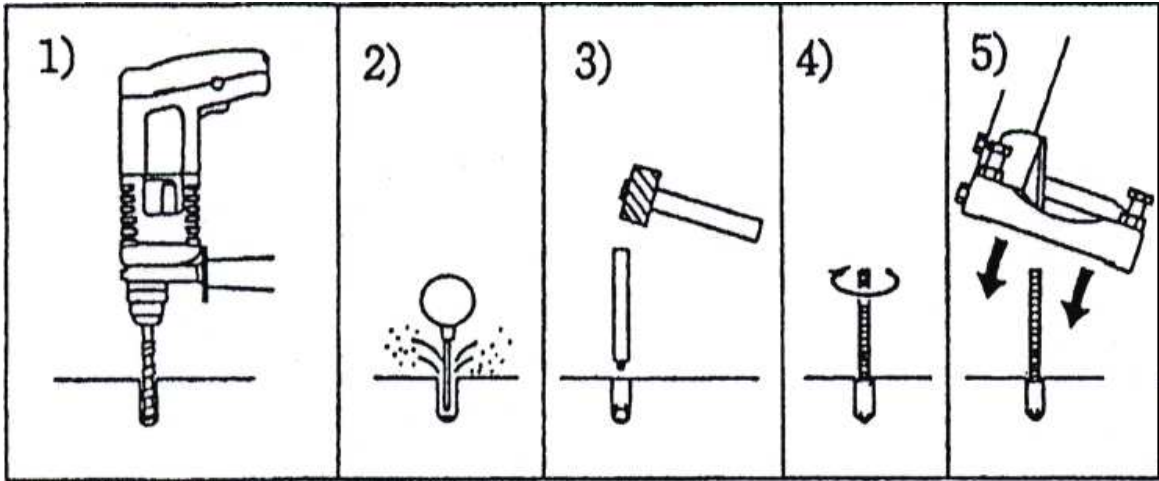

7.1

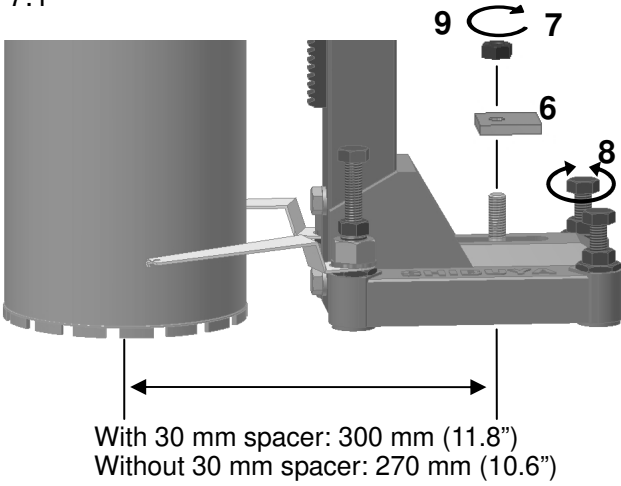

7.1

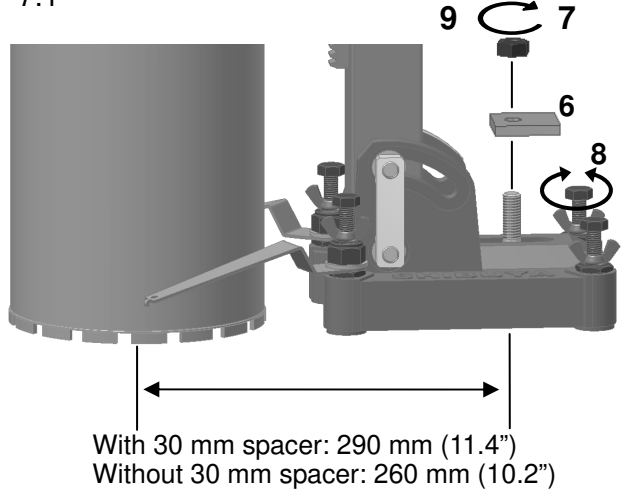

7.2

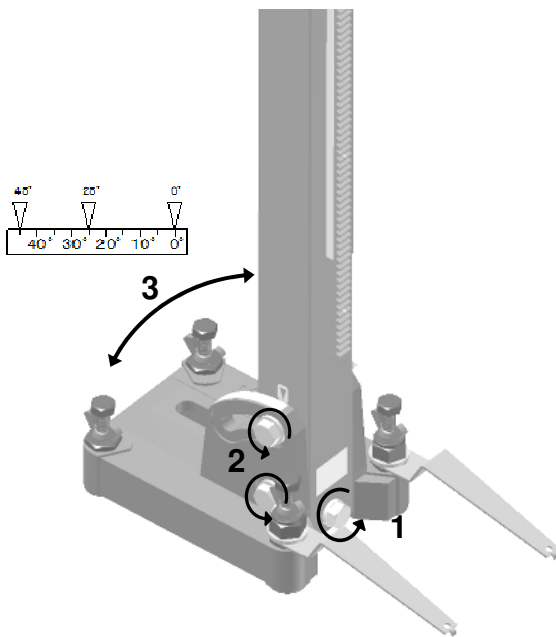

7.2

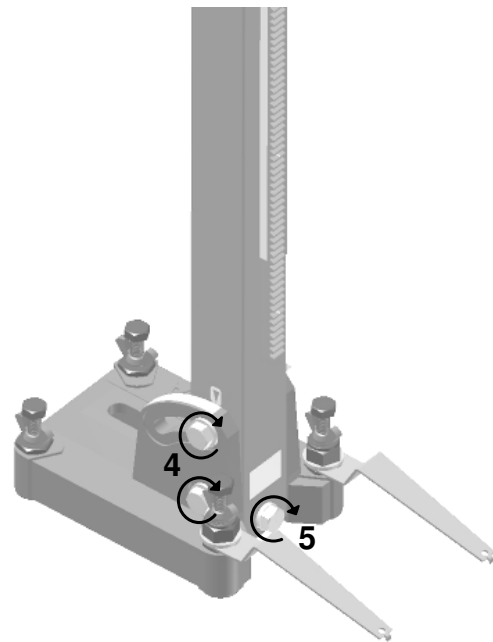

7.3.1

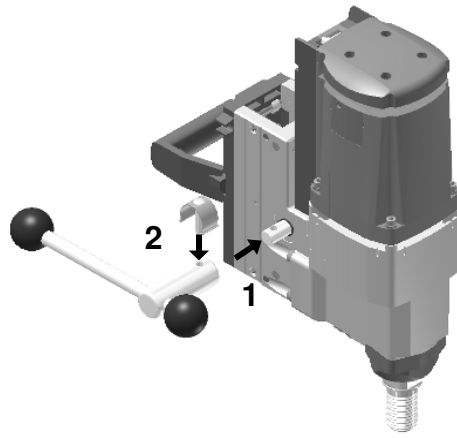

7.3.2

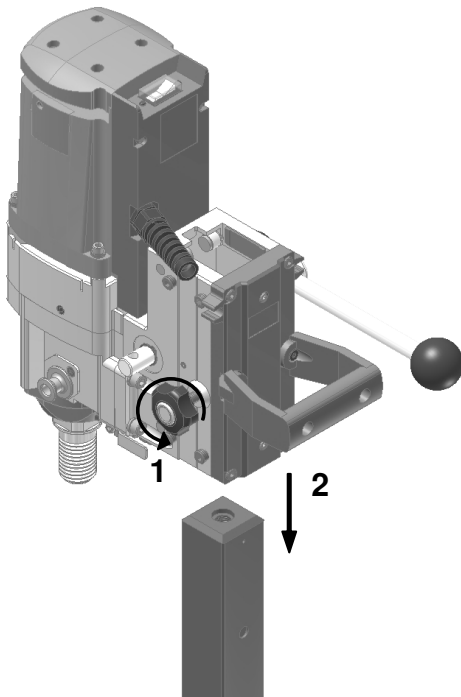

7.3.2

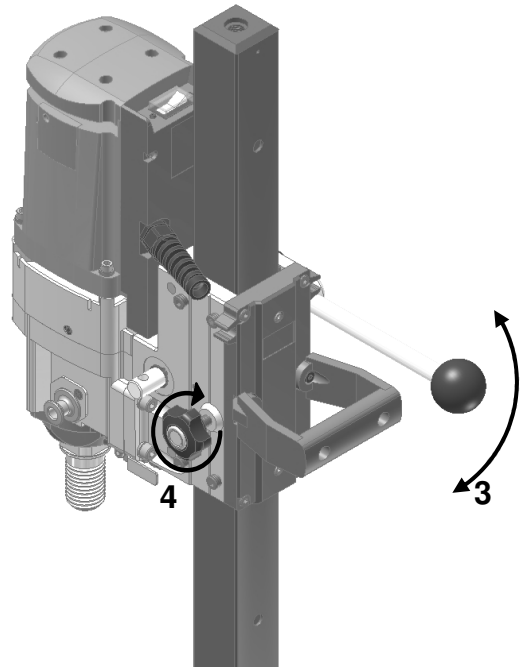

7.3.3

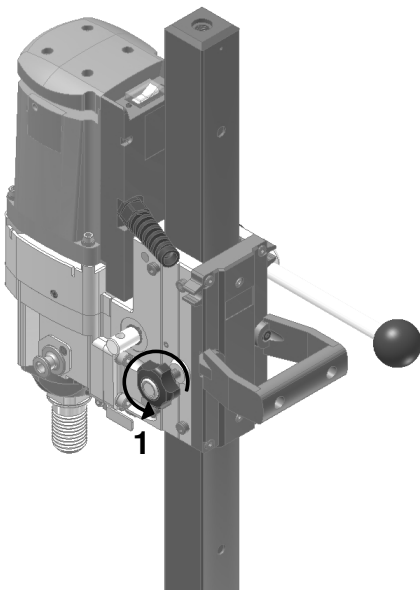

7.3.3

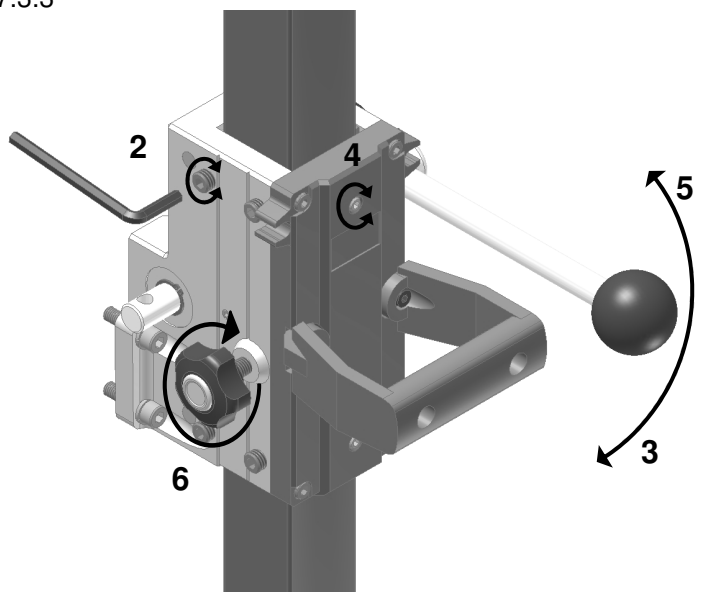

7.4

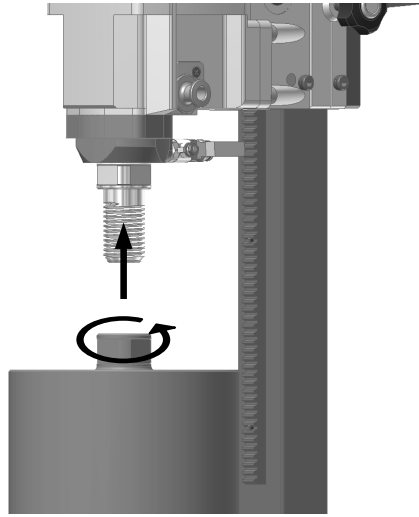

7.5

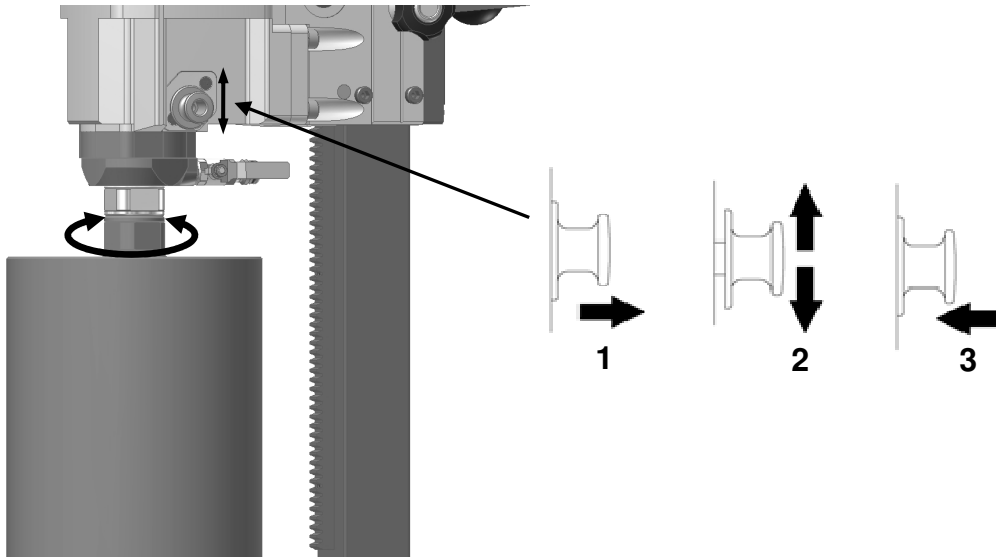

7.6

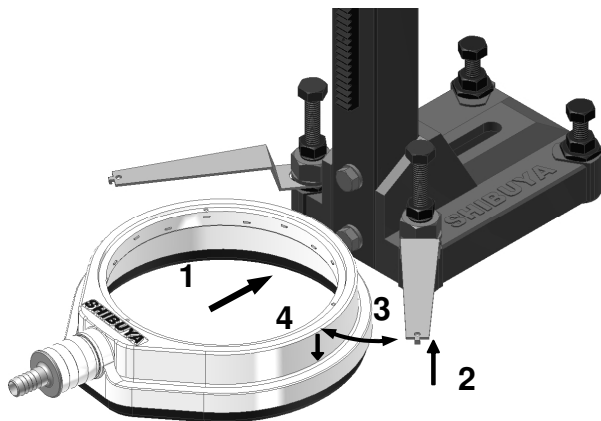

7.7

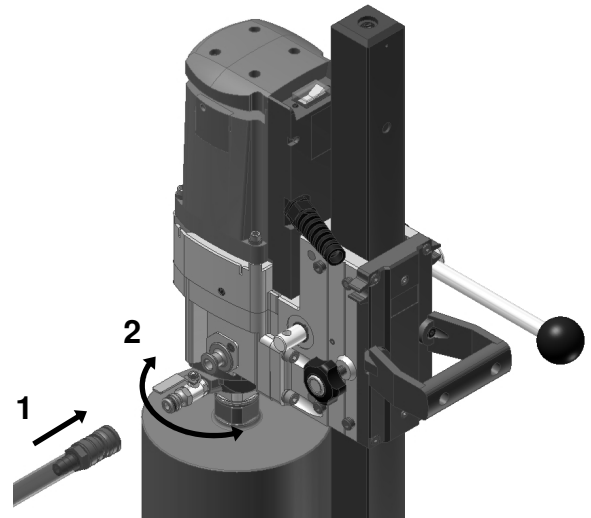

8.2.1

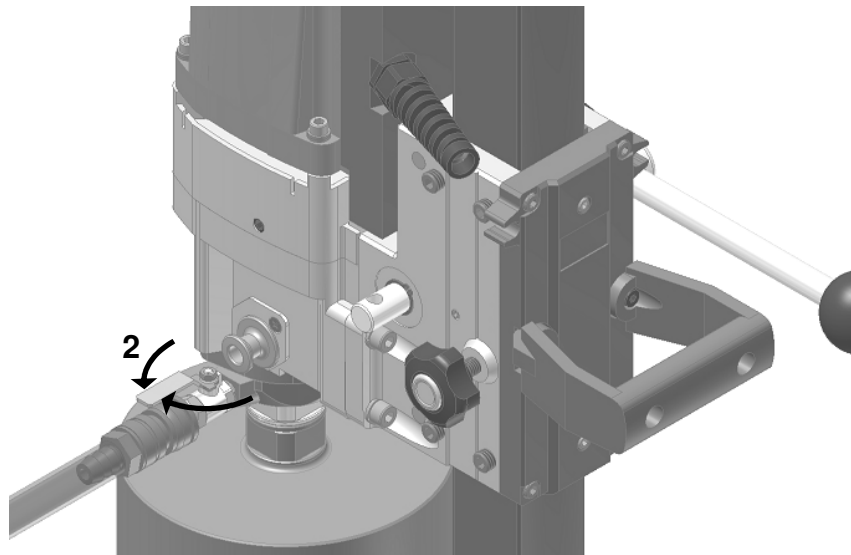

8.2.1

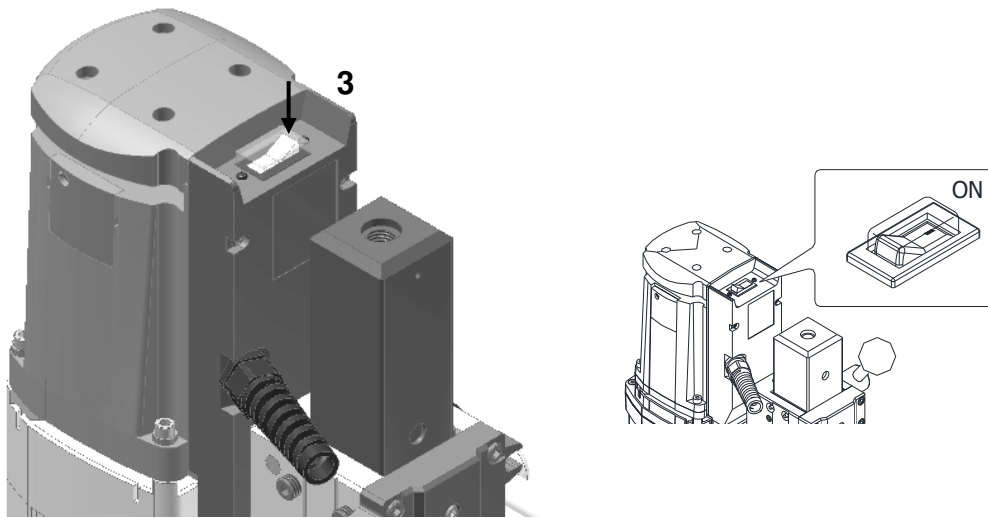

8.2.1

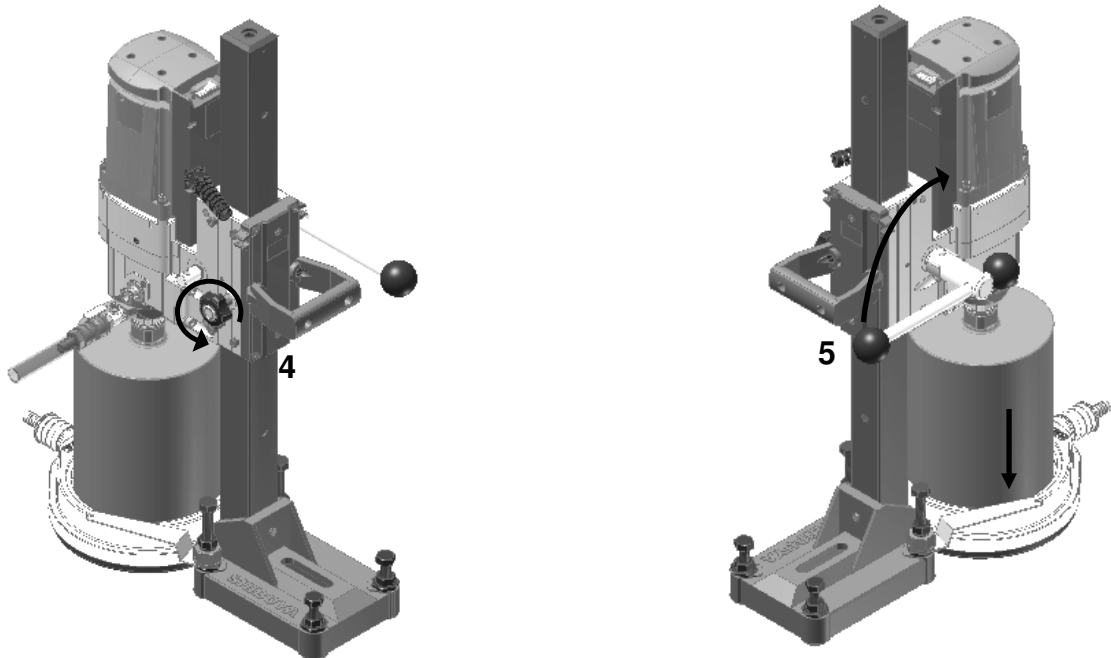

STANDARD ACCESSORIES

Check that all of the following items are included in the package.

TS-255

Item	Size	Qty.	
30 mm Spacer Set		1	
Hex. Socket Bolt	M8x60	4	4
Spring Washer	2-8		
Water Collection Rings	WCR-180	1	

Item in the tool bag	Size	Qty.	
Single-End Spanner	21 mm	1	
Single-End Spanner	36 mm	1	
Allen Key	4 mm	1	
Allen Key	6 mm	1	
Square Washer	W3/8	1	
Core Removal Lasso		1	

TS-255(AB52)

Item	Size	Qty.	
30 mm Spacer Set		1	
Hex. Socket Bolt	M8x60	4	4
Spring Washer	2-8		
Water Collection Rings	WCR-180	1	

Item in the tool bag	Size	Qty.	
Double-End Spanner	17x19 mm	1	
Single-End Spanner	36 mm	1	
Allen Key	4 mm	1	
Allen Key	6 mm	1	
Square Washer	W3/8	1	
Core Removal Lasso		1	

CONTENTS

NAME OF EACH PART	i
ILLUSTRATIONS OF OPERATION	ii
STANDARD ACCESSORIES	vi
CONTENTS	vii
1. GENERAL INFORMATION	1
1.1 Safety notes and their meanings	1
1.2 Pictograms	1
1.3 Model name plate label	2
1.4 Other label	2
2. DESCRIPTION	3
2.1 Applications of the machine	3
3. IMPORTANT NOTICE	3
4. SAFETY	4
4.1 Safety precautions	4
4.1.1 General power tool safety warnings	4
4.1.2 Diamond drill safety warnings	5
4.1.3 Additional safety precautions	6
4.2 Safety devices	7
5. TECHNICAL DATA	8
5.1 Diamond core drilling machine	8
5.2 Noise information and vibration values determined in accordance with EN 62841	9
6. BEFORE USE	10
6.1 Connecting the drill motor with the 30 mm spacer to the carriage block	10
6.2 PRCD, GFCI and RCD	10
6.3 Extension cords	11
7. SETTING UP	11
7.1 Fastening the drill stand with an anchor	11
7.2 Adjusting the angle of the drill stand with AB52	12
7.3 Mounting the drill motor with the carriage block on the drill stand	12
7.3.1 Attaching the quick release handle to the carriage block	12
7.3.2 Attaching the drill motor with the carriage block to the drill stand	12
7.3.3 Adjusting the carriage block	13
7.4 Attaching a core bit	13
7.5 Shifting the gear	14
7.6 Setting a water collection ring	14
7.7 Preparation for water supply	15
8. OPERATION	15
8.1 Precautions for the drilling operation	15
8.1.1 General	15
8.1.2 Electrical safety	15
8.1.3 Others	16
8.2 Operating procedure	16
8.2.1 Start drilling	16
8.2.2 Restart after the circuit protector trips	16
8.2.3 Core bit jamming	16
8.2.4 Stop drilling	17
8.2.5 Remove cores with the core removal lasso	17
9. CLEANING	17
10. ACCESSORIES (OPTION)	18
11. MAINTENANCE	18
11.1 Replacing the carbon brushes	18

12. TRANSPORT AND STORAGE.....	18
13. TROUBLESHOOTING.....	19
14. DISPOSAL.....	20
15. LIMITED WARRANTY	20
16. DIMENSIONS	20
17. PARTS LIST.....	21

1. GENERAL INFORMATION

1.1 Safety notes and their meanings

In this manual, warning signs are classified into four levels based on the level of potential risks.

 **DANGER**

This symbol indicates the imminent risks that lead to death or serious injury to the operators and others, unless the safety instructions are observed.

 **WARNING**

This symbol indicates the potential risks that may lead to death or serious injury to the operators and others, unless the safety instructions are observed.

 **CAUTION**

This symbol indicates the potential risks that lead to injury to the operators and others, unless the safety instructions are observed.

NOTE

This symbol is used for the information that is necessary for you to know.

1.2 Pictograms



Make sure to read and understand this manual thoroughly before starting the operation.



The machine can be a dangerous tool if it is not used correctly. Incorrect and careless use can lead to death or serious injury to the operators and/or others.



Do not dispose of this machine with domestic waste. Follow your national law.

When you dispose of concrete slurry, ask your local authorities for applicable regulations.

1.3 Model name plate label

This machine has a label as shown in the figures below. When the label is illegible or lost, contact a Shibuya authorized dealer to get a new one.
The serial number on the model name plate indicates the production year and month of the drill motor as shown in the sample below.

Model Name Plate Label

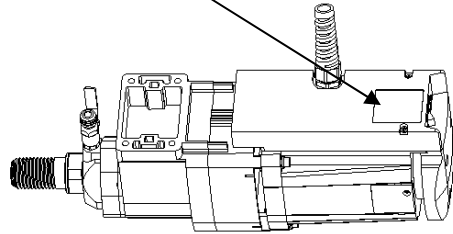

SERIAL (sample): 18 Z 0001

Serial No.
Month (Jan.-Sep.= 1-9, Oct.=X, Nov.=Y, Dec.=Z)
Year (2018)

O	I
DIAMOND CORE DRILLING MACHINE	
MODEL H2021	
STAND	TS-255 800L/1000L/AB52 1000L
RATED VOLTAGE	110 V~
RATED FREQ.	50 Hz
RATED CURRENT	20 A
NO LOAD REV.	450/950 min ⁻¹
MAX.	φ 250 mm
WEIGHT (incl. Carriage Block)	12.2 kg
SERIAL	
SHIBUYA COMPANY, LTD. 5-86 MOKUZAIKO-KITA, HATSUKAICHI, HIROSHIMA 738-0021 JAPAN MADE IN JAPAN	

110 V model

DIAMOND CORE DRILLING MACHINE	
MODEL H2021	
STAND	TS-255 800L/1000L TS-255 AB52 1000L
RATED VOLTAGE	110-120 V~
RATED FREQ.	50/60 Hz
RATED CURRENT	20 A
NO LOAD REV.	450/950 min ⁻¹
MAX.	φ 250 mm
WEIGHT (incl. Carriage Block)	12.2 kg
SERIAL	
SHIBUYA COMPANY, LTD. 5-86 MOKUZAIKO-KITA, HATSUKAICHI, HIROSHIMA 738-0021 JAPAN MADE IN JAPAN	

110-120 V model

DIAMOND CORE DRILLING MACHINE	
MODEL H2021	
STAND	TS-255 800L/1000L TS-255 AB52 1000L
RATED VOLTAGE	220-240 V~
RATED FREQ.	50/60 Hz
RATED CURRENT	15 A
NO LOAD REV.	550/1200 min ⁻¹
MAX.	φ 250 mm
WEIGHT (incl. Carriage Block)	12.2 kg
SERIAL	
SHIBUYA COMPANY, LTD. 5-86 MOKUZAIKO-KITA, HATSUKAICHI, HIROSHIMA 738-0021 JAPAN MADE IN JAPAN	

220-240 V model

1.4 Other label

This machine has labels as shown in the figure below. When the label is illegible or lost, contact a Shibuya authorized dealer to get a new one.

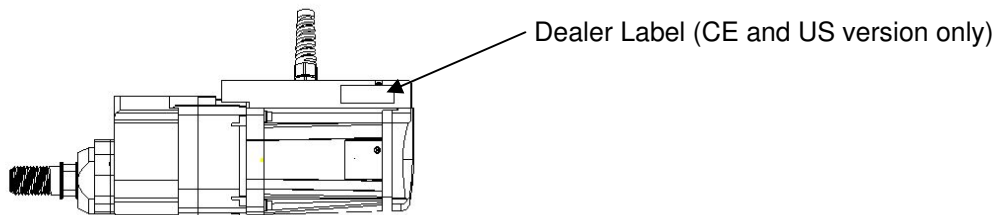

Dealer Label (CE and US version only)

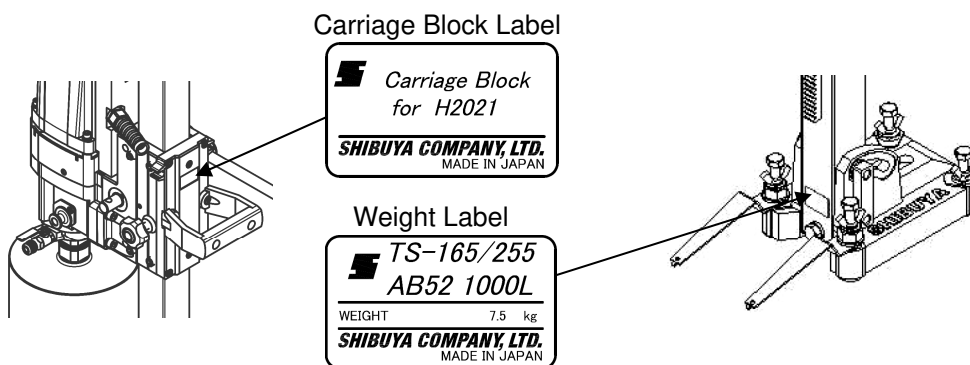

Carriage Block Label

	Carriage Block for H2021
SHIBUYA COMPANY, LTD. MADE IN JAPAN	

Weight Label

	TS-165/255 AB52 1000L
WEIGHT	7.5 kg
SHIBUYA COMPANY, LTD. MADE IN JAPAN	

2. DESCRIPTION

This machine consists of the drill motor and drill stand. This machine is designed for wet drilling in walls and floors made of concrete, natural stone and other mineral building materials using diamond core bits (diamond tools). The drill motor must be mounted on a Shibuya drill stand: TS-255 800L, TS-255 1000L, or TS-255(AB52) 1000L. Handheld use is not permissible.

2.1 Applications of the machine

- Drilling reinforced concrete for piping works
- Extracting concrete cores for strength testing
- Overall drilling in reinforced concrete, except drilling upwards

3. IMPORTANT NOTICE

DANGER

- **Improper use of the diamond core drilling machine may lead to serious or fatal injuries. Read, understand and follow this manual carefully before the operation.**
 - **This machine is designed for core drilling operations. Never use it for any other purposes. Do not use it as a hand-held core drill.**
-

WARNING

- **This machine is intended for industrial applications by experienced operators.**
 - **Always use common sense and plan your work to avoid injuries. It is not possible to cover all risks which may occur during the operations in this manual. Therefore, enough care must be taken to ensure the safe operation of this machine.**
-

NOTE

- Shibuya Company, Ltd. reserves the right to change specifications of products without any prior notices.
 - Copyright reserved on this manual. Publication of the technical information and drawings in this manual, and duplication without prior permission of Shibuya Company, Ltd. is prohibited.
-

4. SAFETY

4.1 Safety precautions

The safety precautions given in the following section contain all general safety precautions for power tools which, in accordance with the applicable standards, require to be listed in the operating instructions.

Accordingly, some of the rules listed may not be relevant to this power tool.

4.1.1 General power tool safety warnings

 **WARNING**

Read all safety warnings, instructions, illustrations and specifications provided with this power tool. Failure to follow all instructions listed below may result in electric shock, fire and/or serious injury.

Save all warnings and instructions for future reference.

The term "power tool" in the warnings refers to your mains-operated (corded) power tool or battery-operated (cordless) power tool.

1) Work area safety

- a) **Keep work area clean and well lit.** Cluttered or dark areas invite accidents.
- b) **Do not operate power tools in explosive atmospheres, such as in the presence of flammable liquids, gases or dust.** Power tools create sparks which may ignite the dust or fumes.
- c) **Keep children and bystanders away while operating a power tool.** Distractions can cause you to lose control.

2) Electrical safety

- a) **Power tool plugs must match the outlet. Never modify the plug in any way. Do not use any adapter plugs with earthed (grounded) power tools.** Unmodified plugs and matching outlets will reduce risk of electric shock.
- b) **Avoid body contact with earthed or grounded surfaces, such as pipes, radiators, ranges and refrigerators.** There is an increased risk of electric shock if your body is earthed or grounded.
- c) **Do not expose power tools to rain or wet conditions.** Water entering a power tool will increase the risk of electric shock.
- d) **Do not abuse the cord. Never use the cord for carrying, pulling or unplugging the power tool. Keep cord away from heat, oil, sharp edges or moving parts.** Damaged or entangled cords increase the risk of electric shock.
- e) **When operating a power tool outdoors, use an extension cord suitable for outdoor use.** Use of a cord suitable for outdoor use reduces the risk of electric shock.
- f) **If operating a power tool in a damp location is unavoidable, use a residual current device (RCD) protected supply.** Use of an RCD reduces the risk of electric shock.

3) Personal safety

- a) **Stay alert, watch what you are doing and use common sense when operating a power tool. Do not use a power tool while you are tired or under the influence of drugs, alcohol or medication.** A moment of inattention while operating power tools may result in serious personal injury.
- b) **Use personal protective equipment. Always wear eye protection.** Protective equipment such as a dust mask, non-skid safety shoes, hard hat or hearing protection used for appropriate conditions will reduce personal injuries.
- c) **Prevent unintentional starting. Ensure the switch is in the off-position before connecting to power source and/or battery pack, picking up or carrying the tool.** Carrying power tools with your finger on the switch or energising power tools that have the switch on invites accidents.
- d) **Remove any adjusting key or wrench before turning the power tool on.** A wrench or a key left attached to a rotating part of the power tool may result in personal injury.

- e) **Do not overreach. Keep proper footing and balance at all times.** This enables better control of the power tool in unexpected situations.
- f) **Dress properly. Do not wear loose clothing or jewellery. Keep your hair and clothing away from moving parts.** Loose clothes, jewellery or long hair can be caught in moving parts.
- g) **If devices are provided for the connection of dust extraction and collection facilities, ensure these are connected and properly used.** Use of dust collection can reduce dust-related hazards.
- h) **Do not let familiarity gained from frequent use of tools allow you to become complacent and ignore tool safety principles.** A careless action can cause severe injury within a fraction of a second.

4) Power tool use and care

- a) **Do not force the power tool. Use the correct power tool for your application.** The correct power tool will do the job better and safer at the rate for which it was designed.
- b) **Do not use the power tool if the switch does not turn it on and off.** Any power tool that cannot be controlled with the switch is dangerous and must be repaired.
- c) **Disconnect the plug from the power source and/or remove the battery pack, if detachable, from the power tool before making any adjustments, changing accessories, or storing power tools.** Such preventive safety measures reduce the risk of starting the power tool accidentally.
- d) **Store idle power tools out of the reach of children and do not allow persons unfamiliar with the power tool or these instructions to operate the power tool.** Power tools are dangerous in the hands of untrained users.
- e) **Maintain power tools and accessories. Check for misalignment or binding of moving parts, breakage of parts and any other condition that may affect the power tool's operation. If damaged, have the power tool repaired before use.** Many accidents are caused by poorly maintained power tools.
- f) **Keep cutting tools sharp and clean.** Properly maintained cutting tools with sharp cutting edges are less likely to bind and are easier to control.
- g) **Use the power tool, accessories and tool bits etc. in accordance with these instructions, taking into account the working conditions and the work to be performed.** Use of the power tool for operations different from those intended could result in a hazardous situation.
- h) **Keep handles and grasping surfaces dry, clean and free from oil and grease.** Slippery handles and grasping surfaces do not allow for safe handling and control of the tool in unexpected situations.

5) Service

- a) **Have your power tool serviced by a qualified repair person using only identical replacement parts.** This will ensure that the safety of the power tool is maintained.

4.1.2 Diamond drill safety warnings

- a) **When performing drilling that requires the use of water, route the water away from the operator's work area or use a liquid collection device.** Such precautionary measures keep the operator's work area dry and reduce the risk of electrical shock.
- b) **Operate power tool by insulated grasping surfaces, when performing an operation where the cutting accessory may contact hidden wiring or its own cord.** Cutting accessory contacting a "live" wire may make exposed metal parts of the power tool "live" and could give the operator an electric shock.
- c) **Wear hearing protection when diamond drilling.** Exposure to noise can cause hearing loss.
- d) **When the bit is jammed, stop applying downward pressure and turn off the tool.** Investigate and take corrective actions to eliminate the cause of the bit jamming.
- e) **When restarting a diamond drill in the workpiece check that the bit rotates freely before starting.** If the bit is jammed, it may not start, may overload the tool, or may cause the diamond drill to release from the workpiece.
- f) **When securing the drill stand with anchors and fasteners to the workpiece, ensure that the anchoring used is capable of holding and restraining the machine during use.** If the workpiece is weak or porous, the anchor may pull out causing the drill stand to release from the workpiece.
- g) **When drilling through walls or ceilings, ensure to protect persons and the work area on the other side.** The bit may extend through the hole or the core may fall out on the other side.

- h) **Do not use this drill tool for overhead drilling with water supply.** Water entering the power tool will increase the risk of electric shock.

4.1.3 Additional safety precautions

Personal safety

- Tampering with or modification of the machine is **not** permitted.
- The machine is **not intended for use by inexperienced persons** who have received no special training.
- Keep the machine out of reach of children.
- **Avoid touching rotating parts.** Switch the machine on only after it is in the position at the workpiece. Touching rotating parts, especially rotating accessory tools, may lead to injury. Use “30mm spacer set” to avoid the feed handle touching to the core bit when using from 200 to 250 mm diameter core bit.
- Avoid skin contact with drilling slurry.
- Dust from materials, such as paint containing lead, some kinds of wood, concrete / masonry / stone containing silica, and minerals as well as metal, may be injurious to health. Contact with or inhalation of the dust may cause allergic reactions and/or respiratory or other diseases to the operator or bystanders. Certain kinds of dust are classified as carcinogenic such as oak and beech dust, especially in conjunction with additives for wood conditioning (chromate, wood preservative). Material containing asbestos must only be handled by specialists. Use a dust removal system that is as effective as possible. Accordingly, use a suitable vacuum cleaner of the type recommended by **specialists** for wood dust and/or mineral dust and which is designed for use with this power tool. Ensure that the workplace is well ventilated. The use of a dust mask suitable for the particular type of dust is recommended. Observe national regulations applicable to the materials on which you intend to use the machine.
- The diamond core drilling machine and the diamond core bit are heavy pieces of equipment. There is a risk of crushing parts of the body. **The user and any other persons in the vicinity must wear suitable eye protection, a hard hat, ear protection, protective gloves and safety footwear while the machine is in use.**

Careful handling and use of electric tools

- Make sure that the drill motor is correctly fastened in the drill stand.
- Ensure that the accessory tools used have a spindle thread that is compatible with the drilling machine and that they are secured in the spindle correctly.

Electrical safety

- **Avoid using extension cords with multiple power outlets** and the simultaneous use of several machines connected to one extension cord.
- Never plug into the socket that is not equipped with an earth (ground) conductor.
- Before beginning work, **check the working area (e.g. using a metal detector) to ensure that no concealed electric cables or gas and water pipes** are present. External metal parts of the machine may become live, for example, when an electric power line is damaged accidentally. This presents a serious risk of electric shock.
- Make sure that the supply cord is not pinched and damaged as the carriage block advances.
- **Never operate the machine without the PRCD.** Never operate machines without an isolating transformer if PRCD is not equipped. Test the PRCD each time before use.
- **Check the machine’s supply cord at regular intervals** and have it replaced by a qualified specialist if found to be damaged. If the machine’s supply cord is damaged it must be replaced by Shibuya authorized dealer. Check extension cords at regular intervals and replace them if found to be damaged. Do not touch the supply cord or extension cord if it is damaged while working. Disconnect the supply cord plug from the power outlet. Damaged supply cords or extension cords present a risk of electric shock.

Workplace

- **Approval must be obtained from the site engineer or architect prior to beginning drilling work.** Drilling work on buildings and other structures may influence the static equilibrium of the structure, especially when steel reinforcing bars or load-bearing components are cut through.
- If the drill stand has not been fastened correctly, always move the drill motor mounted on the drill

- stand all the way down in order to prevent the stand from falling over.
- Keep the supply cord, extension cord, water hose and vacuum hose away from rotating parts of the machine.

4.2 Safety devices

Circuit protector (Main Switch)

⚠ WARNING

Do not modify the circuit protector.

This machine is equipped with a circuit protector for safer operation, avoiding overload of the drill motor which may cause fire or smoke.

Clutch system

⚠ CAUTION

Do not tighten the clutch by yourself.

This machine is equipped with clutch system to reduce the risks when the core bit is jammed. This system also plays a role in protecting the power train.

5. TECHNICAL DATA

5.1 Diamond core drilling machine

When powered by a generator or transformer, the generator or transformer's power output must be at least 4.0 kVA (100 V), 3.5 kVA (110-120 V) or 5.2 kVA (220-240 V). The operating voltage of the transformer or generator must always be the voltage stated on the model name plate label.

The specification may vary for country-specific versions. Please refer to the model name plate label for details of its voltage, frequency, current and input power ratings.

Information for users as per EN 61000-3-11: Switching on causes a brief drop in voltage. Other appliances may be negatively affected on mains supplies where conditions are unfavorable. No malfunctions are to be expected in mains supplies with an impedance of less than 0.162 ohms (220-240 V).

Motor Model		H2021		
Rated Voltage	(V)	100	110 / 110-120	220-240
Rated Frequency	(Hz)	50/60		
Rated Input	(W)	2700	2300	3450
Rated Current	(A)	27	20	15
Spindle Rev. at No Load	(min ⁻¹)	470/1050	450/950	550/1200
Spindle Rev. at Rated Load	(min ⁻¹)	320/720	310/680	300/730
Spindle Thread		UNC 1 1/4" or A-ROD		
Weight (incl. Carriage Block excl. Plug and Cord)	(kg)	12.2 (26.9 lbs.)		

Drill Stand Model		TS-255(800L/1000L)	TS-255(AB52)
Max. Applicable Core Bit Diameter w/ 30 mm Spacer	(mm)	250 (10")	
Overall Height	(mm)	803 (31.6")/1003 (39.5")	1011 (40")
Base Size	(mm)	158 x 217 (6.2" x 8.5")	146 x 205 (5.7" x 8.1")
Total Stroke	(mm)	493 (19.4")/693 (27.3")	680 (26.8")
Max Column Tilt Angle	(°)	-	45
Weight	(kg)	6.6 (14.6 lbs.)/ 7.5 (16.5 lbs.)	7.2 (15.9 lbs.)

NOTE

Never use the machine at the place where the ambient temperature is below 0 degrees C (32 degrees F) or above 40 degrees C (104 degrees F).

5.2 Noise information and vibration values determined in accordance with EN 62841

The sound pressure and vibration values given in these instructions have been measured in accordance with a standardized test and may be used to compare one power tool with another. They may be used for a preliminary assessment of exposure. The data given represents the main applications of the power tool. However, if the power tool is used for different applications, with different accessory tools, or is poorly maintained, the data may vary. This may significantly increase exposure over the total working period. An accurate estimation of exposure should also take into account the times when the power tool is switched off, or when it is running but not actually being used for a job. This may significantly reduce exposure over the total working period. Identify additional safety measures to protect the operator from the effects of noise and/or vibration, for example: maintain the tool and the accessories and organization of work patterns.

The sound pressure and vibration have been measured under the following condition in accordance with EN62841.

Drill motor	Speed range	Core bit dia.	Concrete formulation
H2021 (110 / 220-240 V)	L (Low speed)	200 mm	The water/cement mass ratio : 0.56 Compressive strength : 44 N/mm ²

Noise emission values determined in accordance with EN 62841

Drill motor	H2021 110 V
Sound (power) level (L_{WA})	102.6 dB(A)
Uncertainty for the sound power level (K_{WA})	3 dB(A)
Sound pressure level (L_{pA})	86.6 dB(A)
Uncertainty for the sound pressure level (K_{pA})	3 dB(A)

Drill motor	H2021 220-240 V
Sound (power) level (L_{WA})	105.9 dB(A)
Uncertainty for the sound power level (K_{WA})	3 dB(A)
Sound pressure level (L_{pA})	90.9 dB(A)
Uncertainty for the sound pressure level (K_{pA})	3 dB(A)

Total vibration (vector sum of three directions) measured in accordance with EN 62841

Triaxial total vibration (vector sum of vibration) at the quick release handle (feed handle) does not exceed 2.5 m/s² in accordance with EN 62841.

6. BEFORE USE

When you purchase a complete set that consists of Drill Motor and Drill Stand, the packing is divided into two packages. The drill motor H2021 (including carriage block) in the polyethylene bag is packed in the carton box. The drill stand TS-255(800L/1000L) is packed in the carton box. The drill stand TS-255(AB52) is packed in the carton box. Assemble the components as described in this manual after unpacking.

6.1 Connecting the drill motor with the 30 mm spacer to the carriage block

⚠ WARNING

- **Make sure the drill motor is switched off and disconnected from the power supply.**
- **Comply with the tightening torque stated on this manual. Inadequate torque may lead to death or serious injury to the operators and others.**

Remove 4 pieces of hex. socket bolts (M8x30) fixing the drill motor and the carriage block. Use 4 pieces of hex. socket bolts (M8x60) and 4 pieces of spring washers (2-8) which are supplied with the 30 mm spacer. The tightening torque is 35 Nm (25 lbf·ft) each.

Refer to the figure below.

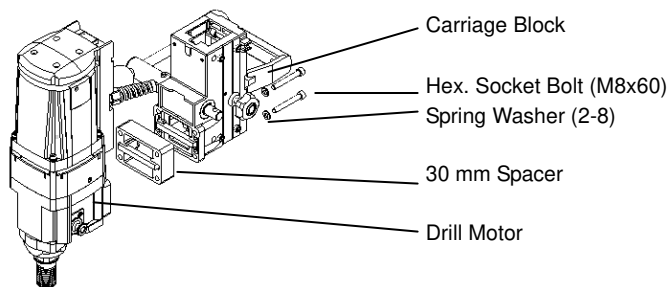

6.2 PRCD, GFCI and RCD

220-240 V model

⚠ WARNING

Always use a Portable Residual Current Device (PRCD) also known as a Ground Fault Circuit Interrupter (GFCI).

Test and reset the PRCD before each use.

1. Plug into an earthed/grounded power outlet.
2. Press the "I" or "RESET" button on the PRCD.
The indicator lights up.
3. Press the "0" or "TEST" button on the PRCD.
The indicator goes out.

100-120 V model

⚠ WARNING

Always use a Residual Current Device (RCD) also known as a Ground Fault Circuit Interrupter (GFCI).

Refer to the manual of the RCD or GFCI.

Specifications of an RCD or GFCI

Power voltage	100-120 V
Breaking current	30 A or more
Current leakage	10 mA or less

6.3 Extension cords

CAUTION

- For 220-240 V model, use only extension cords of a type approved for the application and with conductor cross section 2 mm² or larger, and the maximum allowable length of the cord is 35 meters (115 ft).
- For 110-120 V model, use only extension cords of a type approved for the application and with conductor cross section 2.5 mm² (12AWG) or larger, and the maximum allowable length of the cord is 30 meters (98 ft).
- For 100 V model, use only extension cords of a type approved for the application and with conductor cross section 3.5 mm² (12AWG) or larger, and the maximum allowable length of the cord is 30 meters (98 ft).
- Never turn on the drill motor while the extension cords are circularly bundled. The circularly bundled extension cords may act as a coil which generates a magnetic field and heat.

7. SETTING UP

7.1 Fastening the drill stand with an anchor

DANGER

Fasten the drill stand firmly on the material to be drilled, otherwise the machine may become unstable during the operation and it may lead to death or serious injury to the operators and others.

WARNING

- Read and follow the instruction manual of the anchor bolts used with the machine.
- Use anchor bolts which tensile strength is greater or equal to 24.5 kN (5.5 klbf).
- When fastening the drill stand to a wall, countermeasures must be taken to avoid falling hazards.
- Never fasten the drill stand to a ceiling.

- 1) Drill a hole for Drop-In anchor, using a hammer drill.

The ideal distance between the center of the hole to be drilled and the anchor hole;

TS-255 fixed base drill stand

- a) With 30 mm spacer: 300 mm (11.8")
- b) Without 30 mm spacer: 270 mm (10.6")

TS-255(AB52) swivel base drill stand

- a) With 30 mm spacer: 290 mm (11.4")
- b) Without 30 mm spacer: 260 mm (10.2")

- 2) Clean out the anchor hole.
- 3) Insert the anchor into the hole, and hammer a setting tool to fasten the anchor firmly.
- 4) Screw a threaded bolt into the anchor.
- 5) Set the drill stand, passing the bolt through the anchor slot.
- 6) Insert the W3/8 square washer (standard accessory) to the bolt.
- 7) Insert a hex. nut to the bolt. Then, tighten the nut temporarily.
- 8) Adjust the leveling bolts to stabilize the base. Tighten the nut on the leveling bolts to fix the leveling bolts firmly.
- 9) Tighten the hex. nut firmly using a spanner.

7.2 Adjusting the angle of the drill stand with AB52

⚠ CAUTION

- Before tilting the column, ensure that the drill stand is firmly fastened by an anchor bolt to the material to be drilled, and the drill motor with the carriage block is removed from the column.
- Take care not to pinch fingers between the column and the base.
- Wear protective gloves.

NOTE

The angle scale indicates approximate angle degrees. If higher precision is required, alternative measuring method should be used.

Follow the procedure below.

- 1) Loosen and remove hex. bolt (M12x70) which fixes the column to the base on the front side of the base. Also, remove the spring washers (2-12). Keep them for the future use.
- 2) Loosen 2 pieces of hex. bolts (M12x90) on the side of the column so that the column tilts.
- 3) Tilt the column to a desired angle.
- 4) Tighten 2 pieces of the hex. bolts (M12x90) on the side of the column. The tightening torque is 60 Nm (44 lbf · ft) each.
- 5) When using it as a fixed drill stand, ensure to re-attach hex. bolt (M12x70) and spring washers (2-12) and tighten the bolt. The tightening torque is 60 Nm (44 lbf · ft).

7.3 Mounting the drill motor with the carriage block on the drill stand

⚠ WARNING

Make sure the drill motor is switched off and disconnected from the power supply.

7.3.1 Attaching the quick release handle to the carriage block

⚠ CAUTION

Take care not to pinch fingers between the retainer and the quick release handle (feed handle).

Follow the procedure below.

- 1) Attach the quick release handle (feed handle) to either left or right side of the carriage block.
- 2) Insert the retainer (pin) to fix the quick release handle to the carriage block.
Make sure that the handle is firmly-fastened.

7.3.2 Attaching the drill motor with the carriage block to the drill stand

⚠ CAUTION

- Take care not to pinch fingers between the carriage block and the column when mounting the motor.
- Hold the motor tightly with both hands as below when mounting the motor on the drill stand.
- The quick release handle (feed handle) starts turning once the pinion gear of the carriage block and the rack gear of the column are engaged. Take care not to hit the handle against your body when the carriage block is sliding.
- Tighten the stopper-knob (carriage brake) to prevent unintentional sliding down of the carriage block.

Follow the procedure below.

- 1) Loosen the stopper-knob.
- 2) Mount the drill motor with the carriage block on the drill stand.
- 3) Turn the quick release handle to feed the drill motor to a suitable position.
- 4) Tighten the stopper-knob.

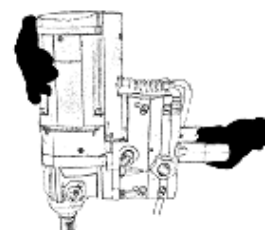

7.3.3 Adjusting the carriage block

NOTE

Adjustment of the carriage block plays an important role in core drilling operations. Unacceptable play of the carriage block will cause a radial runout of the core bit which may lead to unsymmetrical contact of the shank and/or jamming of the core bit while the operation. If the carriage block is too tight, the resistance will increase and the carriage block does not slide smoothly along the column. Adjust the carriage block a little tight and within the operator can reasonably feed the motor.

The carriage block must be adjusted if there is play between the carriage block and the column. Follow the procedure below.

- 1) While holding the feed handle, loosen the stopper-knob.
- 2) Use a 6 mm Allen key to tighten / loosen hex. socket screws.
4 pieces of the hex. socket screws on the left side of the carriage block are for adjusting the play of right and left.
- 3) Turn the feed handle back and forth while checking the play.
- 4) Use a 4 mm Allen key to tighten / loosen hex. socket screws.
2 pieces of the hex. socket screws on the back side of the carriage block are for adjusting the play of back and forth.
- 5) Turn the feed handle back and forth while checking the play.
- 6) Tighten the stopper-knob.

7.4 Attaching a core bit

⚠ WARNING

- **Make sure the drill motor is switched off and disconnected from the power supply.**
 - **Never use the drill motor's power to attach a core bit.**
-

⚠ CAUTION

Wear protective gloves when changing a core bit. A core bit becomes hot as a result of use. It may have sharp edges.

NOTE

- Use core bits in conformity with EN13236 and/or EN12413.
 - For safety reason, each damaged (cracked) bit must be replaced.
 - Leaving a core bit attached to the spindle may cause adherence of the core bit to the spindle. Using a quick disconnect tool such as the Slider may help to avoid such adherence.
-

Attach a core bit to the spindle firmly and securely by rotating the core bit.

Ensure that the end surface of the core bit is aligned with the surface of the spindle, so that the core bit can not be tightened any further.

7.5 Shifting the gear

WARNING

Make sure the drill motor is switched off and disconnected from the power supply.

CAUTION

The gear shifting must be done when the motor is completely stopped.

H2021 drill motor has a 2-speed gearbox. "H" is a high-speed range, and "L" is a low speed range. According to the size or diameter of the core bit attached, a proper gear must be chosen. Refer to the following table.

NOTE

This table is advisory only. Maximum drilling diameter depends on the hardness of the material to be drilled.

Drill Motor Model	Speed Range	Rev. (No-Load)	Recommended Drilling Diameter
H2021	H	1050 min ⁻¹ (100 V) 950 min ⁻¹ (110-120 V) 1200 min ⁻¹ (220-240 V)	Less Than 120 mm (5")
	L	470 min ⁻¹ (100 V) 450 min ⁻¹ (110-120 V) 550 min ⁻¹ (220-240 V)	120 mm to 250 mm (5" to 10")

For the gear shifting procedure, refer to the following.

- 1) Pull out the gear change knob.
- 2) Shift it to your desired position.
- 3) When the shifting is completed, the knob will be pushed back. Ensure that the knob is pushed back to the position before proceeding to the next step.

NOTE

If the gear does not shift well, shift the gear while rotating the spindle by hand.

7.6 Setting a water collection ring

WARNING

- **Make sure the drill motor is switched off and disconnected from the power supply.**
- **Refer to the manual of the water collection ring.**

Follow the procedure below.

- 1) Place a water collection ring.
- 2) Pull the beams.
- 3) Slide the beams on the ring.
- 4) Release the beams on the ring.

7.7 Preparation for water supply

CAUTION

- Ensure that the water hose is not entangled with the core bit or other moving parts.
- Ensure that the water hose has an enough length for the working stroke of the carriage block.
- Ensure that the water hose is not damaged.
- Check the water supply system to ensure there are no leaks.
- Never allow water to enter the drill motor.

NOTE

- The maximum water pressure is 3 bar.
- Use only water (tap water or fresh water).
- Maximum water temperature: 40 degrees C (104 degrees F).

Follow the procedure below.

- 1) Connect a water hose from a tap or a water supplying device to the Gardena connector / water cock of the drill motor.
- 2) Turn the swivel ring and adjust the hose position properly.

8. OPERATION

8.1 Precautions for the drilling operation

DANGER

- The following instructions are essential safety measures that you must follow.
- Improper use may lead to death or serious injury to the operators and/or others.

Ensure the following before plugging in.

8.1.1 General

- Ensure that the operator has read and understood this manual.
- Ensure that the operator wears proper protective clothing such as a hard hat, protective glasses, hearing protection, dust mask, protective gloves, and non-skid safety shoes. Long hair must be tied up.
- Depending on the applicable standard, take care not to stay in the environment which exceeds the allowable sound level for a long time.
- Confirm that the core bit is attached to the spindle properly. When it is misaligned or loose, attach it again.
- Take care not to get your face close to the air outlet.
- Do not insert your hands, arms, face, and other body parts in the working range of the carriage block.

8.1.2 Electrical safety

- Never use this machine without a PRCD, GFCI or RCD.
- Do not drill in an upward from the horizontal. Water may leak in the motor.
- When drilling walls, a proper water collection device must be used.
- Check that the power supply voltage is the voltage shown on the model name plate label of the power tool. If the voltage is low, the current likely increases therefore the circuit protector trips frequently.
- Secure enough current for the machine.
- Use a correctly functioning generator or transformer.
- When powered by a generator or transformer, the generator or transformer's power output must be at least 4.0 kVA (100 V), 3.5 kVA (110-120 V) or 5.2 kVA (220-240 V).
- Make sure that there is no damage on the power plug, cord, and power outlet. If there is any damage, contact a Shibuya authorized dealer for repair.
- Never turn on the drill motor while the extension cords are circularly bundled. The circularly bundled extension cords may act as a coil which generates a magnetic field and heat.
- Before connecting to the power supply, make sure that the main switch is in OFF (0) position. If the main switch is in ON (I) position, the drill motor unintentionally starts off when applying current, which may lead to injury to the operator or others.

8.1.3 Others

- Ensure that the following portions are firmly installed;
 - a) Base and the surface of the material to be drilled.
 - b) Column and carriage block.
 - c) Carriage block and drill motor.
- Ensure that power cord, water hose, and operator's protective clothing are not touching the core bit.
- Ensure that the air inlet of the drill motor which is located on the top side of the motor is not blocked. Insufficient cooling may lead to damage of the motor.
- Ensure that any adjusting keys, wrenches, and spanners are not attached to the machine before starting the operation and while in operation.

8.2 Operating procedure

8.2.1 Start drilling

DANGER

- **Ensure that the operator (s) stand firmly, and keep people away from the working area before starting.**
- **For penetration works, ensure to have proper protection for the operators as well as the people and property at the opposite side of the wall or down floor.**
- **Keep your hands and other body parts away from rotating parts while the drill motor is running.**
- **Do not apply too much pressure to the feed handle at the start of drilling. Rapid start of drilling may shatter segments of the core bit and the pieces may cause injuries. Gradually increase the pressure until stable feeding rate.**
- **Do not touch the metal parts of the feeding handle except the ball knob(s). It may cause electric shock and pinching fingers.**

Follow the procedure below.

- 1) Insert the plug into the power outlet via a PRCD, GFCI or RCD.
For the use of a PRCD, GFCI and RCD, refer to the clause 6.2.
- 2) Open the water cock to start supplying water.
- 3) Turn on the main switch to start the drill motor.
- 4) Loosen the stopper-knob, and start feeding the carriage block by turning the feed handle until the core bit contacts with the drilling surface.
- 5) When the tip of the core bit comes into contact, apply only light pressure until the segments of core bit completely get into the material. Then, gradually increase the pressure until stable feeding rate.

8.2.2 Restart after the circuit protector trips

WARNING

The main switch still remains at ON (I) position even after the drill motor is forced to shut off due to situations such as the electric power failure. To avoid unintentional restart of the motor, ensure to turn off (O) the main switch immediately, after the motor is forced to shut off.

This drill motor is equipped with a circuit protector to protect the motor. The circuit protector trips when it detects overcurrent during the operation.

To restart the drill motor, turn on the main switch again. Adjust the feed pressure so that the circuit protector does not trip.

8.2.3 Core bit jamming

WARNING

- **Make sure the drill motor is switched off and disconnected from the power supply.**

If the core bit is jammed, follow the procedure below to remove the concrete core before restarting the drill motor.

- 1) Close the water cock to stop water supply.
- 2) Unplug the drill motor from the power supply.
- 3) Remove the concrete core.
- 4) Insert the plug into the power outlet via a PRCD, GFCI or RCD again.
For the use of a PRCD, GFCI and RCD, refer to the clause 6.2.
- 5) Open the water cock to start supplying water.
- 6) Turn on the main switch to restart the drill motor.

8.2.4 Stop drilling

⚠ WARNING

Do not let the water and/or concrete slurry splash on the drill motor, cable, plug, and the power supply.

Follow the procedure below.

- 1) When the core bit reaches the desired depth, turn the feed handle backwards to pull out the core bit from the surface of the drilling object.
- 2) Tighten the stopper-knob to fix the carriage block on the column.
- 3) Turn off the main switch to stop the drill motor.
- 4) Close the water cock to stop water supply.
- 5) Unplug the drill motor, and then remove the core bit from the spindle.
- 6) Loosen the stopper-knob, and turn the feed handle to pull up the carriage block until the upper end of the column.
- 7) Lift up and remove the drill motor with the carriage block from the column.
- 8) Remove the drill stand from the surface of the drilling object.

8.2.5 Remove cores with the core removal lasso

⚠ WARNING

- **The core removal lasso is designed for concrete core removal purpose only. Never use it for any other purposes.**
- **Even though this tool has enough wire length to pull up 250 mm (10") diameter cores, the maximum applicable core size depends on the weight and length of the core, and situations.**

Follow the procedure shown in the illustration below.

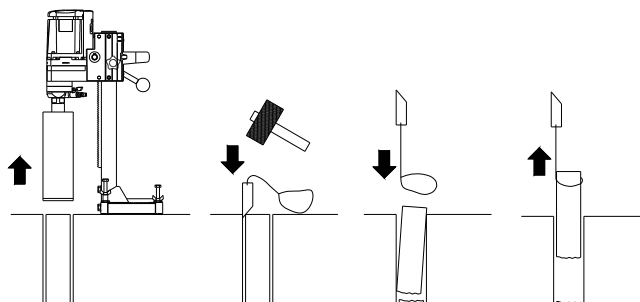

9. CLEANING

⚠ WARNING

- **Always disconnect the drill motor from power supply before starting any maintenance, cleaning, and inspection.**
- **Never immerse the drill motor in water or any other kind of liquid. It may cause electric shocks to the operator and others, and short circuit of the motor.**

Cleaning procedure is following.

- 1) Ensure that the drill motor is unplugged from power supply, before start cleaning.
- 2) Wipe off each part of the drill motor with a wet towel which was tightly wrung.
- 3) Wipe off each part of the drill stand with a wet towel.
- 4) Wash away concrete slurry stuck on the base, the leveling bolts, and the column.
- 5) Rub each part of the machine with a dry cloth.

10. ACCESSORIES (OPTION)

Following items are available as optional accessories.

- 1 : Water Tank
- 2 : Water collection rings and fixtures

11. MAINTENANCE

⚠ WARNING

- Make sure the drill motor is switched off and disconnected from the power supply.
- Use only genuine Shibuya spare parts for the maintenance written in this manual.
- Repairs excluding the maintenance written in this manual must be carried out by qualified, skilled personnel. The safety of the power tool can thus be maintained.

11.1 Replacing the carbon brushes

Inspect the remaining length of the carbon brushes every 100 operating hours. If the carbon brushes are worn down to 7 mm or less, replace them with new carbon brushes. Ensure to replace both sides of carbon brushes as a pair.

NOTE

Always replace both carbon brushes as a pair. Use Shibuya genuine carbon brushes (carbon brush: 049626).

Follow the procedure below.

- 1) Loosen the screw on the brush cover with a Phillips screwdriver, and remove the brush cover.
- 2) Pull out the fasten terminal of the carbon brush from the brush holder with a flat-blade screwdriver.
- 3) Pick up the spring, and pull out the carbon brush while holding the spring with your fingers.
- 4) Insert a carbon brush into the brush holder.
- 5) Release the spring to hold the center of the carbon brush.
- 6) Connect the fasten terminal to the brush holder.
- 7) Fix the brush cover with the screw. Pay attention not to pinch the lead wire with the brush cover.

Loosen the screw

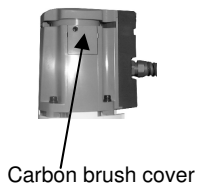

Remove the brush cover

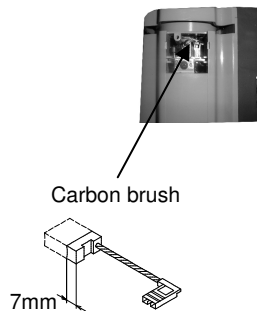

Take out the carbon brush

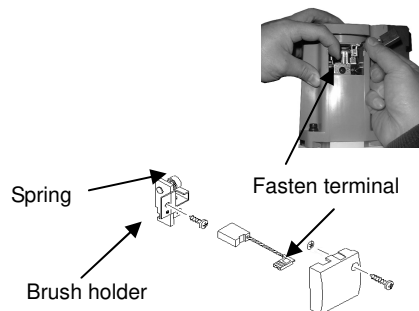

12. TRANSPORT AND STORAGE

⚠ WARNING

Store the machine in a lockable area. Keep out of reach of children and unauthorized persons.

NOTE

- Never store the machine at the place where the ambient temperature is below 0 degrees C (32 degrees F) or above 40 degrees C (104 degrees F). Also, never store the machine where the ambient pressure is below 80 kPa (12 psi). Store the machine in dry conditions.
- Keep the feed handle and the grip handle dry, clean, and free from oil and grease.
- Transport the drill motor, the drill stand and the core bit as separate units. Hold the drill motor (with carriage block) tightly by the grip handle.

13. TROUBLESHOOTING

Trouble	What to do first	Possible Causes	Countermeasures
The drill motor does not start.	(1) Turn off the main switch. (2) Turn off the PRCD (220-240V) and unplug the drill motor from the power supply.	Fault in the electric supply	Plug the drill motor into another power supply and check whether the drill motor works. Check the extension cord, RCD/GFCI/PRCD, power supply, and the outlet. Replace them if necessary.
		Other power tools are plugged into the power supply.	Disconnect the other power tools from the power supply. Secure at least 4.0 kVA (100 V), 3.5 kVA (110-120V) or 5.2 kVA (220-240V) for the drill motor.
		The power cable/plug is damaged.	Contact a Shibuya authorized dealer.
		The main switch is damaged.	Contact a Shibuya authorized dealer.
		The armature/field coil is damaged.	Contact a Shibuya authorized dealer.
		The carbon brushes are worn out.	Replace the carbon brushes.
The motor runs, but the core bit does not revolve well / abnormal noises.	(1) Turn off the main switch. (2) Check the PRCD (220-240V). (3) Check that the gear change knob is shifted properly. (4) Check the core bit.	The gear change knob is not shifted properly.	Shift the gear change knob to engage gears properly.
		The clutch is worn or loose.	Contact a Shibuya authorized dealer.
		Gears are worn or damaged.	Contact a Shibuya authorized dealer.
		Fragments of working materials such as rebar, concrete, stones are jammed between the core bit and the drilled material.	Remove the concrete core from the core bit.
The drill motor shuts off during the operation.	(1) Check whether the circuit protector tripped. (2) Check whether the PRCD tripped (220-240V). (3) Unplug the drill motor from the power supply.	If the circuit protector tripped, the drill motor was overloaded due to apply too much feed pressure.	Restart the drilling, and take care not to apply too much feed pressure.
		If the PRCD tripped, electric leakage was detected or voltage was dropped.	Contact a Shibuya authorized dealer, or an electrical engineer.
		Electric power failure	Check the electric supply with electrical engineer.
Water leaks from the water leakage hole / swivel ring / spindle shaft.	(1) Turn off the main switch. (2) Turn off the PRCD (220-240V) and unplug the drill motor from the power supply. DO NOT TOUCH THE POWER PLUG WITH WET HANDS.	Oil seals are worn.	Contact a Shibuya authorized dealer.
		Water pressure is too high.	Reduce the water pressure to less than 3 bar.
The core bit can not be attached to the spindle.	(1) Check the core bit threads and the spindle threads.	The core bit thread is blocked with dirt or damaged.	Clean the thread, or replace the bit if necessary.
		The spindle thread is blocked with dirt or damaged.	Clean the thread. If the spindle was damaged, contact a Shibuya authorized dealer.
Drilling performance goes down	(1) Turn off the main switch. (2) Turn off the PRCD (220-240V) and unplug the drill motor from the power supply. (3) Check the drainage water from the drilling hole. (4) Check the water supply	If the water contains iron powders, the machine is cutting the rebar(s).	Restart the drilling, and take care not to apply too much feeding pressure.
		Insufficient coolant water	Increase the amount of water supply.
	(5) Check the core bit.	The core bit is worn out, damaged, or defected.	Replace with a new core bit.
		The core bit segments are glazed.	Contact the core bit seller to ask proper sharpening methods.
		Aggregate of concrete is too hard.	Use a core bit with softer segments.
		Maximum drilling depth is reached.	Remove the core and use an extension bar for core bits.
	(6) Jolt the drill motor / stand / core bit to see if it shakes.	The base is not securely fixed to the working material.	Set up the machine again. Redo anchoring securely / Adjust the leveling bolts properly.
		There is play between the carriage block and the column.	Adjust the carriage block.
		Screws which are fastening the base and column, the carriage block and motor are loosened.	Tighten the screws.
	(7) Check for the axial runout of the spindle.	Axial runout of the spindle is observed.	Contact a Shibuya authorized dealer.

14. DISPOSAL



Do not dispose of this machine with domestic waste. Follow your national law.

With regard to environmental aspects, allowing drilling slurry to flow directly into rivers, lakes or the sewerage system without suitable pre-treatment is problematical. Ask your local authorities for applicable regulations.

15. LIMITED WARRANTY

Every Shibuya product is thoroughly inspected and tested before leaving the factory. Should any trouble develop, return the complete machine prepaid to your nearest Shibuya authorized dealer. If inspection shows the trouble is caused by defective workmanship or material, all repairs will be made without charge and the machine will be returned.

This warranty does not apply where;

- 1) Repairs or attempted repairs have been made by persons other than Shibuya authorized dealer.
- 2) Repairs are required because of normal wear.
- 3) The machine has been involved in an accident.
- 4) The machine has been misused.
- 5) The machine has been used after partial failure or normal wear.
- 6) The machine has been modified or used with improper accessories
- 7) The machine expires its warranty period of 1 year upon receipt of the machine.

No other warranty, written or verbal is authorized.

16. DIMENSIONS

Unit: mm [inch]

TS-255 800L/1000L

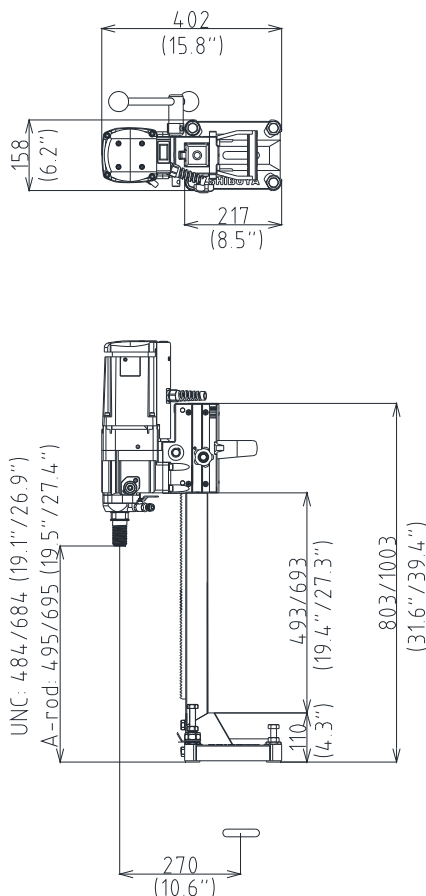

TS-255(AB52) 1000L

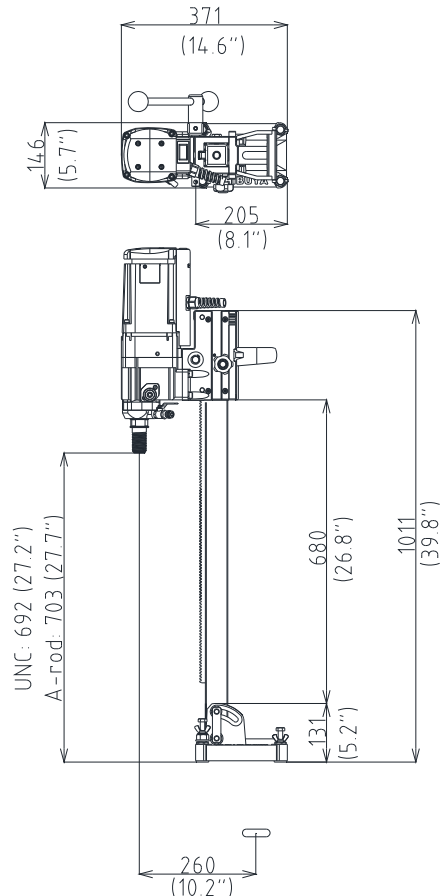

17. PARTS LISTS

H2021 DRILL MOTOR

H2021 100V
110-120V
220-240V
2019-7

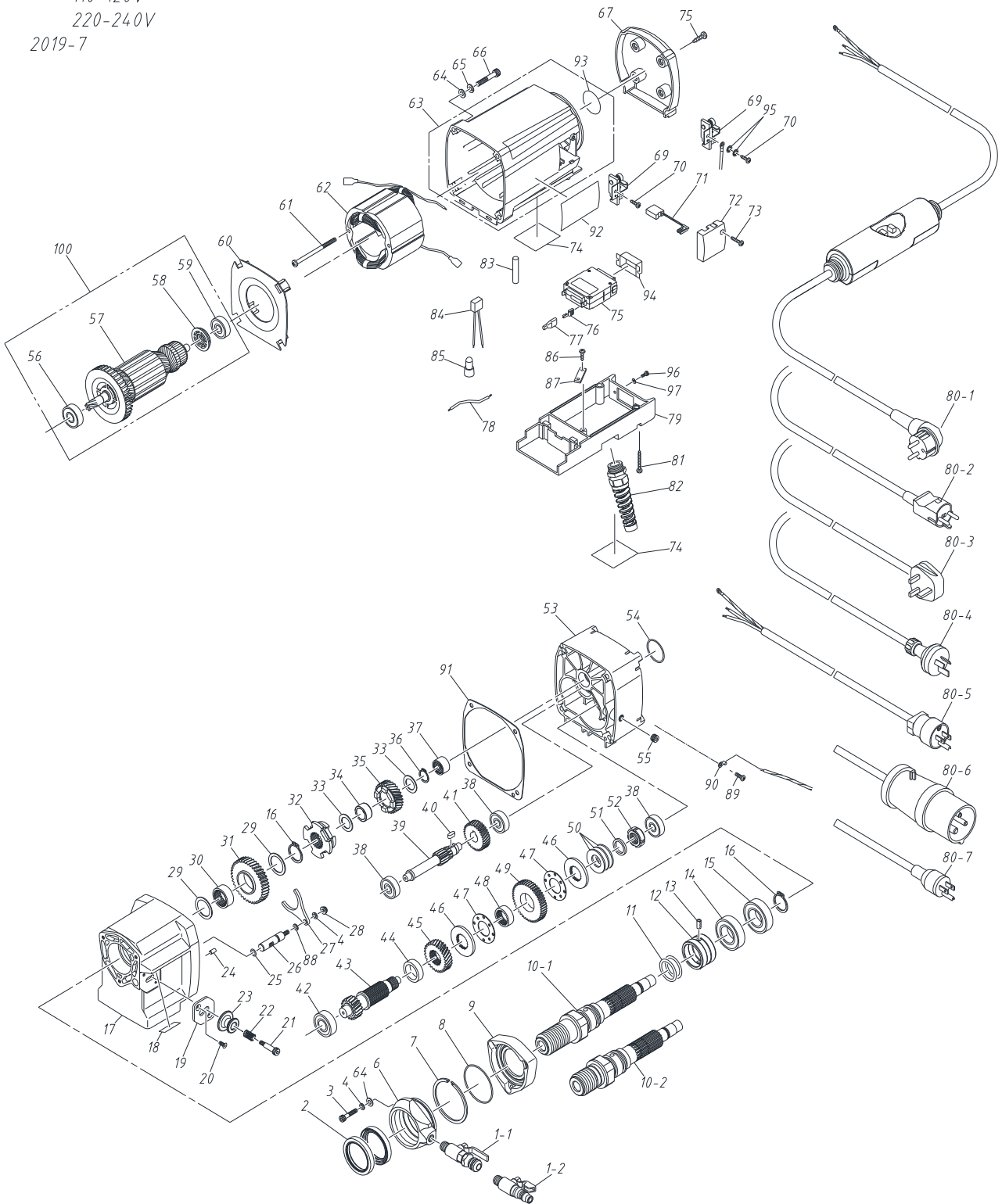

H2021 DRILL MOTOR

POS	PART NAME	NOTE	QTY	CPT CODE
1-1	WATER COCK-GARDENA		1	044137
1-2	WATER COCK-SHIBUYA	1/4-φ16	1	000061
2	OIL SEAL	HMSA42557(SUS)	2	042178
3	HEX. SOCKET BOLT	M5 x 25	3	042179
4	SPRING WASHER	5	4	042180
6	SWIVEL RING		1	051922
7	SNAP RING	SA83	1	005085
8	O-RING	S55	1	042182
9	FIXING RING		1	051923
10-1	SPINDLE (U)		1	042728
10-2	SPINDLE (A)		1	042727
11	O-RING	P28	2	000070
12	SEAL RING		1	042139
13	SPRING PIN	6 x 12AW(SUS)	1	000004
14	BALL BEARING	6005DDU	1	001694
15	BALL BEARING	6005ZZ	1	041710
16	SNAP RING-C	25	2	000689
17	GEAR CASE		1	051941
18	SHIFT POSITION STICKER		1	042186
19	PLATE		1	042187
20	SCREW COUNTERSUNK	M4 x 10	2	000712
21	STRIPPER BOLT	MSB6.5-20	1	006509
22	COIL SPRING		1	000171
23	KNOB		1	043060
24	PARARREL PIN	A5 x 10	1	008559
25	O-RING	P8	1	042190
26	GEAR CHANGE SHAFT		1	042191
27	LEVER		1	044746
28	U-NUT FLANGED	M5	1	042193
29	SHIM RING		2	042194
30	METAL		1	042195
31	NO. 8 GEAR		1	051933
32	CLUTCH NO.3		1	051946
33	SHIM RING		2	042199
34	METAL		1	042200
35	NO. 6 GEAR		1	042732
36	SNAP RING-C	17	1	000272
37	NEEDLE BEARING	TA 1512 Z/HMK1512	1	004630
38	BALL BEARING	6200ZZ	3	000030
39	NO. 3 GEAR		1	051939
40	PARARREL KEY	5 x 5 x 12	1	042872
41	NO. 2 GEAR		1	042734
42	BALL BEARING	6202ZZ	1	000300
43	NO. 7 GEAR		1	051934
44	RING		1	006514
45	NO. 5 GEAR		1	042736
46	CLUTCH		2	042737
47	WASHER		2	042738
48	METAL		1	042739
49	NO. 4 GEAR		1	051940
50	SPRING PLATE	MDS18-2	3	000014
51	RING		1	006520
52	TWIN FU NUT	TFU03SC	1	041776
53	BALL BEARING COVER		1	051947
54	O-RING	S32	1	005389
55	HEX SOCKET PLUG	1/8	1	005386
56	BALL BEARING	6201HP	1	045618
57-1	ARMATURE 220-240V		1	
57-2	ARMATURE 110-120V		1	

POS	PART NAME	NOTE	QTY	CPT CODE
57-3	ARMATURE 100V		1	052497
58	COLLAR		1	042152
59	BALL BEARING	6200DDW	1	045620
60	FAN CASING		1	043080
61-1	TAPPING SCREW PANHEAD	5 x 85 220-240V	2	043081
61-2	TAPPING SCREW PANHEAD	5 x 80 110-120V	2	042682
62-1	FIELD COIL 220-240V		1	052595
62-2	FIELD COIL 110-120V		1	045979
62-3	FIELD COIL 100V		1	043079
63	MOTOR HOUSING W/DUSTPROOF SEAL		1	051948
64	WASHER	ROUND 6	7	042157
65	SPRING WASHER	2-6	4	042158
66	HEX SOCKET BOLT	M6 x 90	4	042744
67	TAIL COVER		1	051949
68	TAPPING SCREW PANHEAD	5 x 20	4	042161
69	BRUSH HOLDER		2	042162
70	SCREW TRUSS PC	4 x 14	2	042163
71	CARBON BRUSH		2	049626
72	BRUSH COVER		2	051929
73	TAPPING SCREW PANHEAD	4 x 20	2	042166
74-1	MOTOR NAME PLATE 220-240V		2	
74-2	MOTOR NAME PLATE 110-120V		2	
74-3	MOTOR NAME PLATE 100V		2	
75-1	CIRCUIT PROTECTOR 220-240V	NRAR1100-15AAA	1	001944
75-2	CIRCUIT PROTECTOR 110-120V	NRAR1100-22ADA	1	051759
75-3	CIRCUIT PROTECTOR 100V	NRAR1100-30ADA	1	044977
76	FASTEN TERMINAL		2	000057
77	CAP		2	000056
78-1	LEAD WIRE	110-120V/220-240V	1	043135
78-2	LEAD WIRE	100V	2	043097
79	SWITCH BOX		1	043492
80-1	PLUG WITH CABLE & PRCD	220-240V EU/ASIA	1	042218
80-2	PLUG WITH CABLE & PRCD	220-240V DK	1	042783
80-3	PLUG WITH CABLE & PRCD	220-240V SA	1	050972
80-4	PLUG WITH CABLE & PRCD	220-240V AU	1	051170
80-5	PLUG WITH CABLE	110-120V US	1	042781
80-6	PLUG WITH CABLE	110V UK	1	053048
80-7	PLUG WITH CABLE	100V TW	1	045969
81	SCREW HANHEAD B TIGHT	4 x 30	2	042171
82	CABLE SLEEVE	5311 1720	1	052825
83	INSULATION TUBE	φ8 x 40	1	042174
84-1	CONDENSER	0.1 μF/110V UK	1	000059
84-2	CONDENSER	0.1 μF/220-240V	1	000059
85-1	CLOSED-END CONNECTOR	5.5SD / 110-120V/220-240V	2	000055
85-2	CLOSED-END CONNECTOR	5.5SD / 100V	3	000055
86	TAPPING SCREW PANHEAD	4 x 16	2	005495
87	CORD FIXER	6560067	1	042177
88	COLLAR		1	051950
89	SCREW PANHEAD W/SW	M4 x 10	1	000690
90	TERMINAL w/ INSULATION	FVD2-M4	1	045679
91	RUBBER GASKET		1	044737
92	LABEL		1	052180
93	DUSTPROOF SEAL		1	052033
94	DUST COVER	NRAR	1	000131
95	TOOTHED WASHER	TW ONLY	2	043085
96	SCREW PANHEAD W/SW	M3 x 8	2	043093
97	WASHER	3	2	043094
100-1	ARMATURE ASSY 220-240V	56+57+58+59	1	052594
100-2	ARMATURE ASSY 110-120V	56+57+58+59	1	045983
100-3	ARMATURE ASSY 100V	56+57+58+59	1	052498

CARRIAGE BLOCK FOR H2021

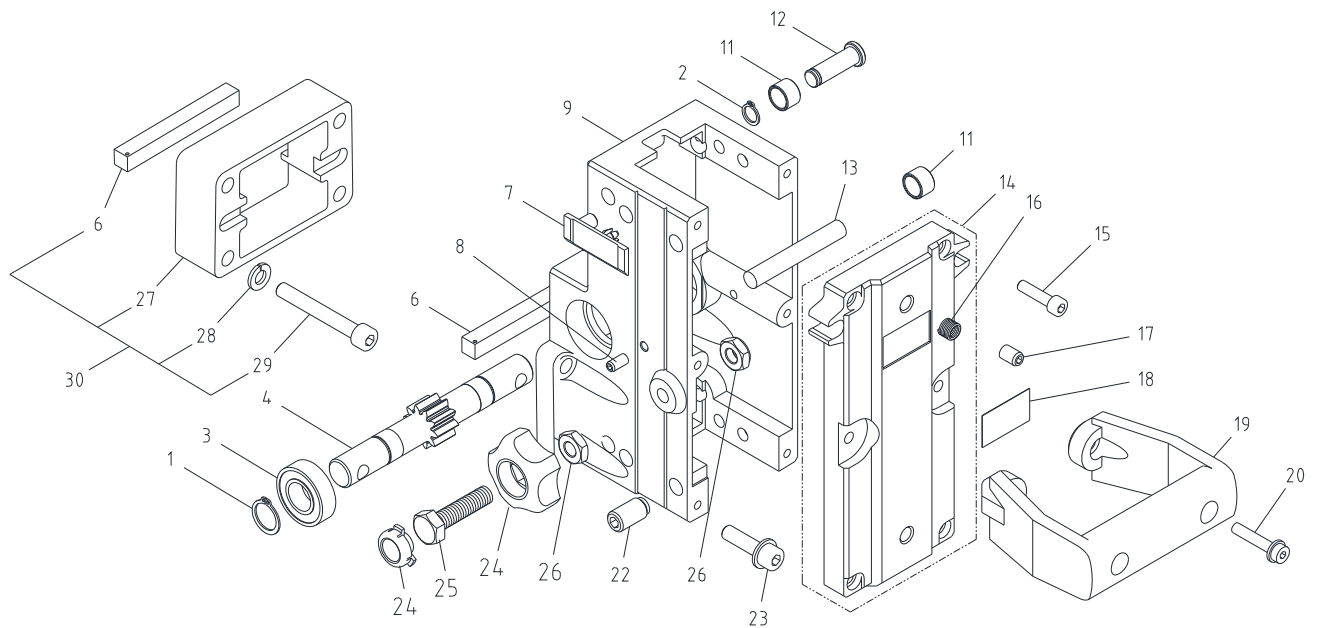

POS	PART NAME	NOTE	QTY	CPT CODE
1	SNAP RING-C	17	2	000272
2	SNAP RING-C	10	4	041411
3	BALL BEARING	6003-2VU	2	048379
4	PINION GEAR		1	051988
6	PARALLEL KEY		2	042637
7	SLIDING PLATE		2	042125
8	HEX SOCKET SCREW	M6 x 12	2	042123
9	CARRIAGE BODY		1	052020
11	ROLLER WITH BUSH		8	049273
12	ROLLER SHAFT(F)		4	052005
13	ROLLER SHAFT(R)		2	042129
14	BACK COVER		1	042634
15	HEX. SOCKET BOLT	M6 x 25	4	042131
16	HELISERT	M8 x 1D	2	000458
17	HEX. SOCKET SCREW	M8 x 12	2	042130
18	WEIGHT LABEL (CARRIAGE BLOCK)		1	
19	GRIP HANDLE (RESIN)		1	042133
20	HEX. SOCKET BOLT FLANGED	M6 x 30	2	042132
22	HEX. SOCKET SCREW		4	042126
23	HEX. SOCKET BOLT w/SW	M8 x 30	4	042391
24	STOPPER-KNOB	M10	1	042268
25	HEX. BOLT	M10 x 40(COPPER)	1	042267
26	U-NUT	3-M10	2	043045
27	30MM SPACER BODY		1	052024
28	SPRING WASHER	2-8	4	042824
29	HEX. SOCKET BOLT	M8 X 60	4	042823
30	30MM SPACER SET		1	052023
	CARRIAGE BLOCK CPL.	excl. POS. 30	1	052910

QUICK RELEASE HANDLE

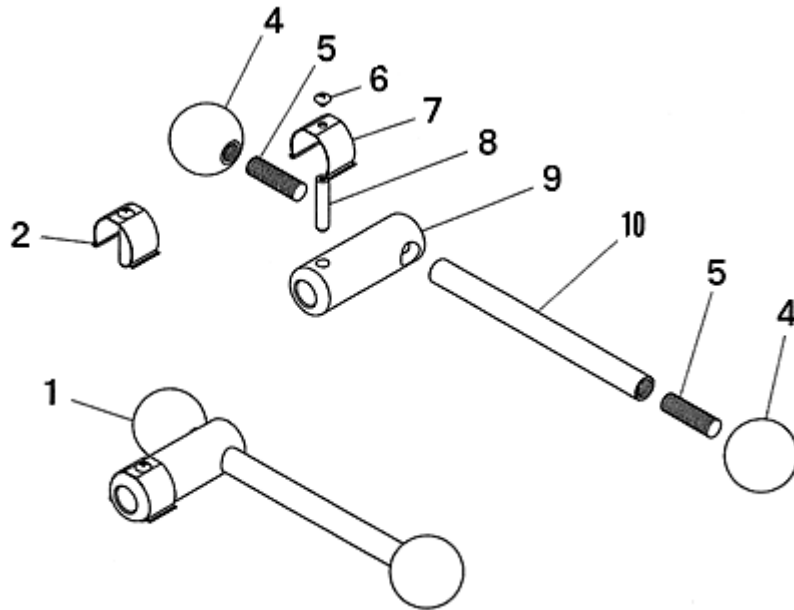

POS	PART NAME	NOTE	QTY	CPT CODE
1	Q.R. HANDLE CPL. (AL)		1	042076
2	RETAINER COMPLETE		1	006095
4	GRIP BALL DIA. 45		2	042113
5	THREADED BOLT	M12 × 40	2	042116
6	SCREW	M5 × 6(SUS)	1	006091
7	SPRING		1	006092
8	PIN		1	006093
9	HANDLE BODY (AL)		1	042115
10	HANDLE ROD (AL)		1	042114

TS-255 BASE AND COLUMN 800L AND 1000L

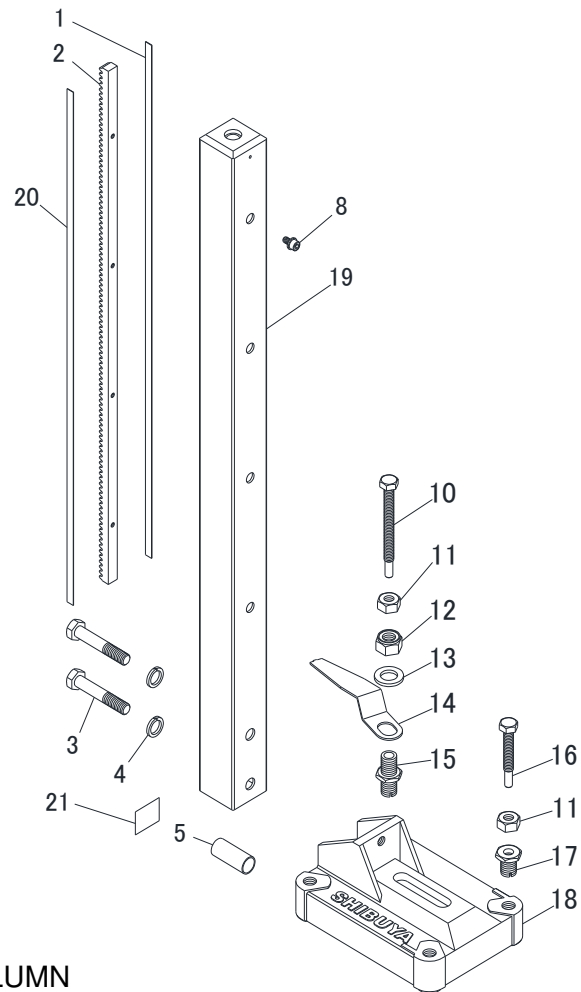

COLUMN

POS	PART NAME	NOTE	QTY	CPT CODE
1	DEPTH GAUGE DECAL (mm)		1	000520
2	RACK GEAR 800L		1	004688
2	RACK GEAR 1000L		1	004670
5	PIPE BOSS		2	005164
8	HEX. SOCKET BOLT	M6 X 12	4 (FOR 800L) 6 (FOR 1000L)	004672
19	COLUMN 800L		1	041944
19	COLUMN 1000L		1	002046
20	DEPTH GAUGE DECAL (inch)	US VERSION ONLY	1	044497
21	WEIGHT LABEL (TS-255 800L)		1	
21	WEIGHT LABEL (TS-255 1000L)		1	
	COLUMN CPL. 800L		1	005659
	COLUMN CPL. 800L US VERSION		1	051678
	COLUMN CPL. 1000L		1	051679
	COLUMN CPL. 1000L US VERSION		1	051680

BASE

POS	PART NAME	NOTE	QTY	CPT CODE
3	HEX. BOLT	M12 X 70	2	042650
4	SPRING WASHER	2-12	2	042098
10	LEVELING BOLT(F)		2	042648
11	HEX. NUT	1 -W1/2	4	042651
12	U-NUT	1-M20	2	042825
13	PLAIN WASHER	20	2	042656
14	BEAM		2	042657
15	HEX. BOSS (F)		2	042652
16	LEVELING BOLT(R)		2	042649
17	HEX. BOSS (R)		2	042653
18	BASE PLATE		1	042646
	TS-255 BASE CPL.		1	042644

AB52 SWIVEL BASE & COLUMN

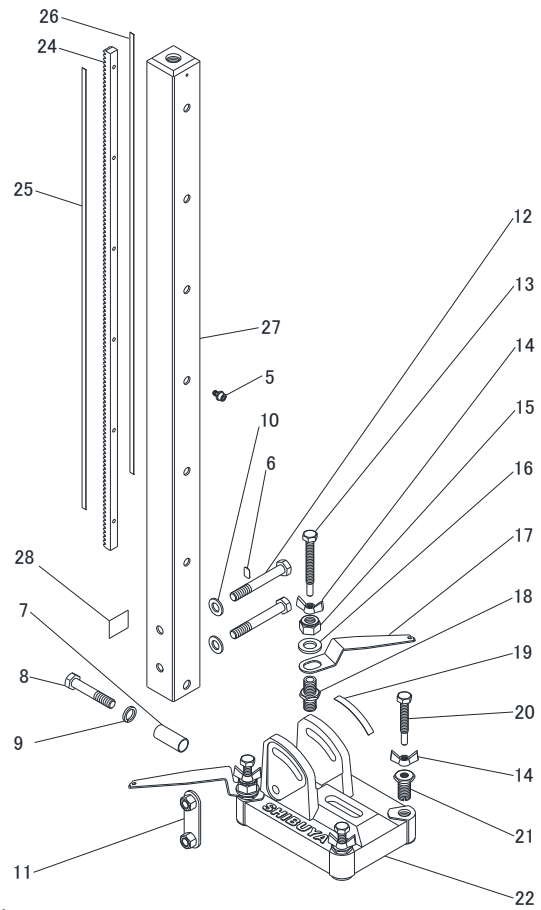

COLUMN

POS	PART NAME	NOTE	QTY	CPT CODE
5	HEX. SOCKET BOLT W/SW	M6 x 12	6	004672
6	INDICATION LABEL		1	000732
7	PIPE BOSS		1	005164
24	RACK GEAR		1	004670
25	DEPTH GAUGE DECAL (mm)		1	000520
26	DEPTH GAUGE DECAL (inch)	US version only	1	044497
27	COLUMN AB52 L1000 M16		1	042929
28	WEIGHT LABEL(AB52)		1	
	COLUMN CPL. L1000		1	051682
	COLUMN CPL. L1000 US VERSION		1	051683

BASE

POS	PART NAME	NOTE	QTY	CPT. CODE
8	HEX. BOLT	M12 x 70	1	042650
9	SPRING WASHER	2-12	1	042098
10	WASHER	φ 12.5 x φ 28 x t3.2	2	042826
11	PLATE (N)		1	052533
12	HEX. BOLT	M12 x 90 (10.9)	2	042827
13	LEVELING BOLT (F)		2	042094
14	FLANGE NUT	2-M10	4	042096
15	U-NUT	3-M16	2	042101
16	PLAIN WASHER	POLISHED ROUND 16	2	042100
17	BEAM		2	042099
18	HEX. BOSS 2 (F)		2	042092
19	ANGLE SCALE		1	006478
20	LEVELING BOLT (R)		2	042095
21	HEX. BOSS 2 (R)		2	042093
22	BASE PLATE		1	042828
	AB52 SWIVEL BASE CPL.		1	042796

EU DECLARATION OF CONFORMITY

SHIBUYA COMPANY, LTD.
5-86, MOKUZAIKO-KITA, HATSUKAICHI, HIROSHIMA 738-0021 JAPAN
declares, in sole responsibility, that the following equipment

Drill Stand Model TS-255 with H2021 Drill Motor (110 V), Country of Origin: Japan
Drill Stand Model TS-255(AB52) with H2021 Drill Motor (110 V), Country of Origin: Japan
Drill Stand Model TS-255 with H2021 Drill Motor (220-240 V), Country of Origin: Japan
Drill Stand Model TS-255(AB52) with H2021 Drill Motor (220-240 V), Country of Origin: Japan

Serial No.:

Referred to in this declaration conforms with the following directive(s):

Machinery Directive 2006/42/EC, Annex I, Annex IIA

Harmonized standards: EN 62841-1:2015, EN 62841-3-6:2014
EN ISO 12100:2010

EMC Directive 2014/30/EU

Harmonized standards: EN 55014-1:2006+A1:2009+A2:2011, EN 55014-2:1997+A1:2001+A2:2008
EN 61000-3-2:2014, EN 61000-3-3:2013, EN 61000-3-11:2000

RoHS Directive 2011/65/EU

Authorized representative / Importer in UK;

DYMATEC LTD
Units 11-14 Cemetery Road, Houghton Regis, Bedfordshire, LU5 5BZ, United Kingdom
Mr. Jeremy David Newton

The person authorized to compile the technical file;

Mr. Jeremy David Newton
Units 11-14 Cemetery Road, Houghton Regis, Bedfordshire, LU5 5BZ, United Kingdom

Note: This declaration becomes invalid if technical or operational modifications are introduced without the manufacturer's consent.

Hiroshima, 6/2019
Kazuyoshi Shibuya, Director
SHIBUYA COMPANY, LTD.

UK DECLARATION OF CONFORMITY

SHIBUYA COMPANY, LTD.

5-86, MOKUZAIKO-KITA, HATSUKAICHI, HIROSHIMA 738-0021 JAPAN

declares, in sole responsibility, that the following equipment

Drill Stand Model TS-255 with H2021 Drill Motor (110 V), Country of Origin: Japan

Drill Stand Model TS-255(AB52) with H2021 Drill Motor (110 V), Country of Origin: Japan

Serial No.: 2240001 - UP

referred to in this declaration conforms with the following regulation (s):

The Supply of Machinery (Safety) Regulations 2008

Harmonized standards: EN 62841-1:2015, EN 62841-3-6:2014

EN ISO 12100:2010

The Electromagnetic Compatibility Regulations 2016

Harmonized standards: EN 55014-1:2006+A1:2009+A2:2011, EN 55014-2:1997+A1:2001+A2:2008

EN 61000-3-2:2014, EN 61000-3-3:2013, EN 61000-3-11:2000

The Restriction of the Use of Certain Hazardous Substances

in Electrical and Electronic Equipment Regulations 2012

Authorized representative / Importer in UK;

DYMATEC LTD

Units 11-14 Cemetery Road, Houghton Regis, Bedfordshire, LU5 5BZ, United Kingdom

Mr. Jeremy David Newton

The person authorized to compile the technical file;

Mr. Jeremy David Newton

Units 11-14 Cemetery Road, Houghton Regis, Bedfordshire, LU5 5BZ, United Kingdom

Note: This declaration becomes invalid if technical or operational modifications are introduced without the manufacturer's consent.

Hiroshima, 4/2022

Kazuyoshi Shibuya, President & CEO

SHIBUYA COMPANY, LTD.

EU DECLARATION OF CONFORMITY

SHIBUYA COMPANY, LTD.

5-86, MOKUZAIKO-KITA, HATSUKAICHI, HIROSHIMA 738-0021 JAPAN

declares, in sole responsibility, that the following equipment

Drill Stand Model TS-255 with H2021 Drill Motor (110 V), Country of Origin: Japan

Drill Stand Model TS-255(AB52) with H2021 Drill Motor (110 V), Country of Origin: Japan

Drill Stand Model TS-255 with H2021 Drill Motor (220-240 V), Country of Origin: Japan

Drill Stand Model TS-255(AB52) with H2021 Drill Motor (220-240 V), Country of Origin: Japan

Serial No.:

Referred to in this declaration conforms with the following directive(s):

Machinery Directive 2006/42/EC, Annex I, Annex IIA

Harmonized standards: EN 62841-1:2015, EN 62841-3-6:2014

EN ISO 12100:2010

EMC Directive 2014/30/EU

Harmonized standards: EN 55014-1:2006+A1:2009+A2:2011, EN 55014-2:1997+A1:2001+A2:2008

EN 61000-3-2:2014, EN 61000-3-3:2013, EN 61000-3-11:2000

RoHS Directive 2011/65/EU

Authorized representative / Importer in UK;

DIAQUIP

Unit 1, Whitefield Road Ind. Est, Bredbury, Stockport SK6 SQR. United Kingdom

The person authorized to compile the technical file;

Mr. Jonathan Shaw

Unit 1, Whitefield Road Ind. Est, Bredbury, Stockport SK6 SQR. United Kingdom

Note: This declaration becomes invalid if technical or operational modifications are introduced without the manufacturer's consent.

Hiroshima, 6/2019

Kazuyoshi Shibuya, Director

SHIBUYA COMPANY, LTD.

UK DECLARATION OF CONFORMITY

SHIBUYA COMPANY, LTD.

5-86, MOKUZAIKO-KITA, HATSUKAICHI, HIROSHIMA 738-0021 JAPAN

declares, in sole responsibility, that the following equipment

Drill Stand Model TS-255 with H2021 Drill Motor (110 V), Country of Origin: Japan

Drill Stand Model TS-255(AB52) with H2021 Drill Motor (110 V), Country of Origin: Japan

Serial No.: 2240001 - UP

referred to in this declaration conforms with the following regulation (s):

The Supply of Machinery (Safety) Regulations 2008

Harmonized standards: EN 62841-1:2015, EN 62841-3-6:2014

EN ISO 12100:2010

The Electromagnetic Compatibility Regulations 2016

Harmonized standards: EN 55014-1:2006+A1:2009+A2:2011, EN 55014-2:1997+A1:2001+A2:2008

EN 61000-3-2:2014, EN 61000-3-3:2013, EN 61000-3-11:2000

The Restriction of the Use of Certain Hazardous Substances

in Electrical and Electronic Equipment Regulations 2012

Authorized representative / Importer in UK;

DIAQUIP

Unit 1, Whitefield Road Ind. Est, Bredbury, Stockport SK6 SQR. United Kingdom

The person authorized to compile the technical file;

Mr. Jonathan Shaw

Unit 1, Whitefield Road Ind. Est, Bredbury, Stockport SK6 SQR. United Kingdom

Note: This declaration becomes invalid if technical or operational modifications are introduced without the manufacturer's consent.

Hiroshima, 4/2022

Kazuyoshi Shibuya, President & CEO

SHIBUYA COMPANY, LTD.

DECLARATIE DE CONFORMITATE EU

SHIBUYA COMPANY, LTD.

5-86, MOKUZAIKO-KITA, HATSUKAICHI, HIROSHIMA 738-0021 JAPAN

declară pe proprie răspundere că următoarele echipamente :

Stand de carotare TS-255 cu Motor de carotare H2021 (220-240 V), tara de origine: Japonia

Stand de carotare TS-255(AB52) cu Motor de carotare H2021 (220-240 V), tara de origine: Japonia

Seria Nr.:

Respecta urmatoarele directive europene:

Directiva **2006/42/EC**, Annex I, Annex IIA privind echipamentele tehnice

Standardele armonizate : EN 62841-1:2015, EN 62841-3-6:2014

EN ISO 12100:2010

Directiva EMC **2014/30/EU**

Standardele armonizate: EN 55014-1:2006+A1:2009+A2:2011, EN 55014-2:1997+A1:2001+A2:2008

EN 61000-3-2:2014, EN 61000-3-3:2013, EN 61000-3-11:2000

Directiva RoHS **2011/65/EU**

Reprezentant autorizat/Importator in Romania:

ANTREPRIZA CONTRACTON SRL

STR. FRUMUSANI, NR. 12, BL. 100, SC.2, AP 63,

SECTOR 4, BUCURESTI, ROMANIA

MR. DANIEL TELER

Persoana autorizata sa intocmeasca fisa tehnica:

MR. DANIEL TELER

STR. FRUMUSANI, NR. 12, BL. 100, SC.2, AP 63,

SECTOR 4, BUCURESTI, ROMANIA

Nota: Această declarație devine nulă în cazul în care modificările tehnice sau operaționale sunt introduse fără acordul producătorului.

Hiroshima, 6/2019

Kazuyoshi Shibuya, Director

SHIBUYA COMPANY, LTD.

UE – DEKLARACJA ZGODNOŚCI

SHIBUYA COMPANY, LTD.

5-86, MOKUZAIKO-KITA, HATSUKAICHI, HIROSHIMA 738-0021 JAPONIA

oświadcza, na własną i wyłączną odpowiedzialność, że następujący sprzęt:

Statyw wiertarki Model TS-255 z silnikiem H2021 (220-240 V), Kraj pochodzenia: Japonia

Statyw wiertarki Model TS-255(AB52) z silnikiem H2021 (220-240 V), Kraj pochodzenia: Japonia

Numer seryjny:

o którym mowa w niniejszej deklaracji spełnia następujące dyrektywy:

Dyrektywę Maszynową **2006/42/EC**, Annex I, Annex IIA

Ujednolicone normy: EN 62841-1:2015, EN 62841-3-6:2014

EN ISO 12100:2010

Dyrektywa dotyczy kompatybilności elektromagnetycznej **2014/30/EU**

Ujednolicone normy: EN 55014-1:2006+A1:2009+A2:2011, EN 55014-2:1997+A1:2001+A2:2008

EN 61000-3-2:2014, EN 61000-3-3:2013, EN 61000-3-11:2000

Dyrektywę RoHS **2011/65/EU**

Autoryzowany przedstawiciel / Importer w Polsce;

BETON-TECHNIK

Ul.28 Czewca 56r. Nr. 159/1, 61-505 Poznan, Polska

Osoba upoważniona do wykonania dokumentacji technicznej;

Pana Kazimierza Lewandowskiego

Ul.28 Czewca 56r. Nr. 159/1, 61-505 Poznan, Polska

Uwaga: Niniejsza deklaracja staje się nieważna jeśli bez zgody producenta wprowadzone zostały modyfikacje techniczne lub operacyjne.

Hiroshima, 6/2019

Kazuyoshi Shibuya, Dyrektor

SHIBUYA COMPANY, LTD.

EU SAMSVARERKLÆRING

SHIBUYA COMPANY, LTD.
5-86, MOKUZAIKO-KITA, HATSUKAICHI, HIROSHIMA 738-0021 JAPAN
erklærer, på eget ansvar, at følgende utstyr:

Borstativ Modell TS-255 med H2021 motorenhet (220-240 V), Varens opprinnelsesland:Japan
Borstativ Modell TS-255(AB52) med H2021 motorenhet (220-240 V), Varens opprinnelsesland:Japan

Serienummer:

Nevnt i denne erklæring er i samsvar med følgende direktiv(er)

Maskin direktiv **2006/42/EC**, Annex I, Annex IIA
Harmonisert standard: EN 62841-1:2015, EN 62841-3-6:2014
EN ISO 12100:2010

EMC Direktiv **2014/30/EU**
Harmonisert standard: EN 55014-1:2006+A1:2009+A2:2011, EN 55014-2:1997+A1:2001+A2:2008
EN 61000-3-2:2014, EN 61000-3-3:2013, EN 61000-3-11:2000

RoHS Direktiv **2011/65/EU**

Importør i Norge

LEVANTO NORGE AS
PER KROHGS VEI 4C
1065 OSLO
NORWAY
MR. PATRICK SANDMAN
TLF : +47 22 90 61 50

Personen som er autorisert til å samle og dokumentere teknisk informasjon;

LEVANTO OY
Venevalkamantie 5, 02700 Kauniainen, Finland

Merk: Denne deklarasjonen blir ugyldig om tekniske eller operasjonelle modifikasjoner blir utført uten produsentens tillatelse.

Hiroshima, 6/2019
Kazuyoshi Shibuya, Direktør
SHIBUYA COMPANY, LTD.

EU OVERENSSTEMMELSESERKLÆRING

SHIBUYA COMPANY, LTD.
5-86, MOKUZAIKO-KITA, HATSUKAICHI, HIROSHIMA 738-0021 JAPAN
Erklærer hermed, under eget ansvar, at det følgende udstyr

Borestander Model TS-255 med H2021 Boremotor (220-240 V), Oprindelsesland: Japan
Borestander Model TS-255(AB52) med H2021 Boremotor (220-240 V), Oprindelsesland: Japan

Serienummer:

Henvist til I denne erklæring, er I overensstemmelse med retningslinjerne I nedennævnte direktiver:

Maskindirektiv 2006/42/EC, Annex I, Annex IIA

Harmoniserede standarder: EN 62841-1:2015, EN 62841-3-6:2014

EN ISO 12100:2010

EMC-direktiv 2014/30/EU

Harmoniserede standarder: EN 55014-1:2006+A1:2009+A2:2011, EN 55014-2:1997+A1:2001+A2:2008

EN 61000-3-2:2014, EN 61000-3-3:2013, EN 61000-3-11:2000

RoHS-direktiv 2011/65/EU

Autoriseret repræsentant/forhandler og importør i DANMARK;

J.D. Diamantværktøj A/S

Glentevej 33, DK-4600 Køge, Denmark

Personen der er autoriseret til udarbejde/oversætte den tekniske fil;

Teknisk ansvarlig: Mr. Hans Henrik Danielsen

Glentevej 33, DK-4600 Køge, Denmark

Note: Denne erklæring anses for værende ugyldig, såfremt der er foretaget tekniske eller operationelle modifikationer, uden producentens samtykke.

Hiroshima, 6/2019

Kazuyoshi Shibuya, Director

SHIBUYA COMPANY, LTD.

EY-VAATIMUSTENMUKAISUUSVAKUUTUS

SHIBUYA COMPANY, LTD.
5-86, MOKUZAIKO-KITA, HATSUKAICHI, HIROSHIMA 738-0021 JAPAN
vakuuttaa omalla vastuullaan, että tässä vakuutuksessa mainitut laitteet:

Porakonejalusta, malli TS-255, H2021-moottorilla (220-240 V) varustettu porakone, alkuperämaa: Japani
Porakonejalusta, malli TS-255(AB52), H2021-moottorilla (220-240 V) varustettu porakone, alkuperämaa: Japani

Sarja No.:

ovat seuraavan direktiivin (seuraavien direktiivien) mukaisia:

Konedirektiivi **2006/42/EC**, Annex I, Annex IIA

Yhdenmukaiset standardit: EN 62841-1:2015, EN 62841-3-6:2014
EN ISO 12100:2010

EMC-direktiivi **2014/30/EU**

Yhdenmukaiset standardit: EN 55014-1:2006+A1:2009+A2:2011, EN 55014-2:1997+A1:2001+A2:2008
EN 61000-3-2:2014, EN 61000-3-3:2013, EN 61000-3-11:2000

RoHS-direktiivi **2011/65/EU**

Valtuutettu edustaja Suomessa;

LEVANTO OY

Venevalkamantie 5, 02700 Kauniainen, Suomi

Teknillisten tiedostojen kääntämiseen valtuutettu henkilö;

Patrick Sandman

Venevalkamantie 5, 02700 Kauniainen, Suomi

Huomaa: Tämä vakuutus lakkaa olemasta voimassa, jos teknisiä tai käyttöön liittyviä muutoksia tehdään ilman valmistajan suostumusta.

Hiroshima, 6/2019

Kazuyoshi Shibuya, Toimitusjohtaja

SHIBUYA COMPANY, LTD.

DÉCLARATION DE CONFORMITÉ EU

SHIBUYA COMPANY, LTD.
5-86, MOKUZAIKO-KITA, HATSUKAICHI, HIROSHIMA 738-0021 JAPAN
déclare sous sa seule responsabilité que les équipements suivants :

Bâti de carottage TS-255 avec moteur de carottage H2021 (220-240 V), Pays d'origine: Japon
Bâti de carottage TS-255(AB52) avec moteur de carottage H2021 (220-240 V), Pays d'origine: Japon

No de série:

Sont conformes aux directives européennes suivantes :

Directive Machines **2006/42/EC**, Annex I, Annex IIA

Normes harmonisées: EN 62841-1:2015, EN 62841-3-6:2014
EN ISO 12100:2010

Directive CEM **2014/30/EU**

Normes harmonisées: EN 55014-1:2006+A1:2009+A2:2011, EN 55014-2:1997+A1:2001+A2:2008
EN 61000-3-2:2014, EN 61000-3-3:2013, EN 61000-3-11:2000

Directive RoHS **2011/65/EU**

Représentant autorisé / Importateur en France;

PEUVREL OUTILS DIAMANTÉS
35 rue La Maison-Neuve, 35270 BONNEMAIN, FRANCE

La personne autorisée à compiler le dossier technique;

Mr. Julien Peuvrel
35 rue La Maison-Neuve, 35270 BONNEMAIN, FRANCE

Note: Cette déclaration devient invalide si des modifications techniques ont lieu sans l'accord du fabricant.

Hiroshima, 6/2019
Kazuyoshi Shibuya, Directeur
SHIBUYA COMPANY, LTD.

EU SAMSVARERKLÆRING

SHIBUYA COMPANY, LTD.
5-86, MOKUZAIKO-KITA, HATSUKAICHI, HIROSHIMA 738-0021 JAPAN
erklærer, på eget ansvar, at følgende utstyr:

Borstativ Modell TS-255 med H2021 Drivmotor (220-240 V), Varens opprinnelsesland: Japan
Borstativ Modell TS-255(AB52) med H2021 Drivmotor (220-240 V), Varens opprinnelsesland: Japan

Serienummer:

Nevnt i denne erklæring i samsvar med følgende direktiv(er)

Maskin direktiv **2006/42/EC**, Annex I, Annex IIA

Harmonisert standard: EN 62841-1:2015, EN 62841-3-6:2014
EN ISO 12100:2010

EMC Direktiv **2014/30/EU**

Harmonisert standard: EN 55014-1:2006+A1:2009+A2:2011, EN 55014-2:1997+A1:2001+A2:2008
EN 61000-3-2:2014, EN 61000-3-3:2013, EN 61000-3-11:2000

RoHS Direktiv **2011/65/EU**

Importør i Norge

SVERRE HELLUM & SØNN AS
LINDEBERG NAERINGSVEI 28, 1067 OSLO
NORWAY
MR. GLENN HELLUM
TEL : +47 23 17 81 00

Tekniskansvarlig for utforming av de tekniskefilene;
J.D. DIAMOND TOOLS A/S
GLENTEVEJ 33, DK-4600 KOGE, DENMARK

Merk: Denne deklarasjonen blir ugyldig om tekniske eller operasjonelle modifikasjoner blir utført uten produsentens tillatelse

Hiroshima, 11/2022
Kazuyoshi Shibuya, President & CEO
SHIBUYA COMPANY, LTD.

ES ATITIKTIES DEKLARACIJA

SHIBUYA COMPANY, LTD.
5-86, MOKUZAIKO-KITA, HATSUKAICHI, HIROSHIMA 738-0021 JAPONIJA
Deklaruoja, kad sekantys gaminiai:

Gręžimo stovo modelis TS-255 su H2021 gręžimo varikliu (220-240 V), Kilmės šalis: Japonija
Gręžimo stovo modelis TS-255(AB52) su H2021 gręžimo varikliu (220-240 V), Kilmės šalis: Japonija

Serijos Nr.:

Atitinka sekančias direktyvas:

Mašinų direktyva **2006/42/EC**, Annex I, Annex IIA

Atitinka standartus: EN 62841-1:2015, EN 62841-3-6:2014

EN ISO 12100:2010

Elektromagnetinio suderinamumo direktyva **2014/30/EU**

Atitinka standartus: EN 55014-1:2006+A1:2009+A2:2011, EN 55014-2:1997+A1:2001+A2:2008

EN 61000-3-2:2014, EN 61000-3-3:2013, EN 61000-3-11:2000

RoHS direktyva **2011/65/EU**

Autorizuotas atstovas / Importuotojas Lietuvoje;

MONTEZA UAB

Pranciškonų 4A-23, Lt-01133 Vilnius, Lietuva

Asmuo įgaliotas parengti techninę dokumentaciją;

Andrius Montvydas

Pranciškonų 4A-23, Lt-01133 Vilnius, Lietuva

Pastaba: ši deklaracija tampa negaliojanti jei techninės modifikacijos buvo atliktos be gamintojo sutikimo.

Hiroshima, 7/2021

Kazuyoshi Shibuya, Direktorius

SHIBUYA COMPANY, LTD.

UK DECLARATION OF CONFORMITY

SHIBUYA COMPANY, LTD.

5-86, MOKUZAIKO-KITA, HATSUKAICHI, HIROSHIMA 738-0021 JAPAN

declares, in sole responsibility, that the following equipment

Drill Stand Model TS-255 with H2021 Drill Motor (110 V), Country of Origin: Japan

Drill Stand Model TS-255(AB52) with H2021 Drill Motor (110 V), Country of Origin: Japan

Serial No.: 2240001 - UP

referred to in this declaration conforms with the following regulation (s):

The Supply of Machinery (Safety) Regulations 2008

Harmonized standards: EN 62841-1:2015, EN 62841-3-6:2014

EN ISO 12100:2010

The Electromagnetic Compatibility Regulations 2016

Harmonized standards: EN 55014-1:2006+A1:2009+A2:2011, EN 55014-2:1997+A1:2001+A2:2008

EN 61000-3-2:2014, EN 61000-3-3:2013, EN 61000-3-11:2000

The Restriction of the Use of Certain Hazardous Substances
in Electrical and Electronic Equipment Regulations 2012

Authorized representative / Importer in UK;

GILES ENGINEERING (UK) LTD

Unit 6 Cathcart Court, 50 Cathcart Road, Rutherglen, South Lanarkshire G73 2RA,
Scotland, United Kingdom

Mr. Derek Cummings

The person authorized to compile the technical file;

Mr. Derek Cummings

Unit 6 Cathcart Court, 50 Cathcart Road, Rutherglen, South Lanarkshire G73 2RA,
Scotland, United Kingdom

Note: This declaration becomes invalid if technical or operational modifications are introduced without the manufacturer's consent.

Hiroshima, 2/2023

Kazuyoshi Shibuya, President & CEO

SHIBUYA COMPANY, LTD.

SHIBUYA